



M5180 Value Series Vector Network Analyzer Specifications



Frequency range	300 kHz to 18 GHz
Software	S2VNA or CMT VNA

Revision 26.00 07.07.2026

General Overview

M5180

Frequency range	300 kHz to 18 GHz
Measured parameters	S11, S21, S12, S22
Sweep types	linear frequency, log frequency, segment, power sweep
Dynamic range	>140 dB typ. (10 Hz IF BW)
Measurement speed	30 μ s typ.
Output power adjustment range	-45 dBm to +10 dBm
Measurement points per sweep	up to 500,001

Functionality and Features Overview

- Intuitive software control through a two-level menu, quick access toolbar, channel status bar, and hot keys.
- Multi-channel mode. No limitations on the number of channels, diagrams, traces, or markers.
- Sweep by frequency: linear, logarithmic or segment mode, by power: linear, by time: CW mode.
- The software implements data, memory, and static traces. Available trace functions include trace hold, smoothing, statistical data calculation, and standard mathematical operations.
- Calibration wizard with workflow progress and step guidance. The wizard works in conjunction with the calibration kit and connector libraries. The libraries include numerous predefined items. Multiple calibration methods are supported.
- Fixture simulator includes the port extension feature, embedding and de-embedding functions, and impedance conversion.
- For post-processing of measurement data, markers and limit tests are available. Marker search and marker math functions are supported.
- The software supports time domain measurements with gating.
- All state, calibration and measurement data can be saved to a state file. The software allows the user to save S-parameters to a touchstone file, and an individual trace's data as a CSV file.
- A print function is provided. This function also supports saving data according to a predefined template, with the option to include supplementary information related to the operator, DUT, and experimental conditions.
- Automation programming in Python, LabVIEW, MATLAB, .NET, etc.

CMT VNA Software

The Software Application is Part of the VNA

The analyzers include an RF measurement module, and a software application. The software application takes raw measurement data from the data acquisition (measurement) module and transforms into S-parameters in multiple presentation formats utilizing proprietary algorithms. The calibration and other accuracy enhancing algorithms were developed by our metrology experts.

The instruments use CMT VNA software, which can be installed on x86- or ARM-based processors and controlled via a USB interface. The software features an intuitive user interface with all available options organized in sub-menus, enabling quick and efficient navigation between different functions.

M5180 Value Series Vector Network Analyzer Specifications

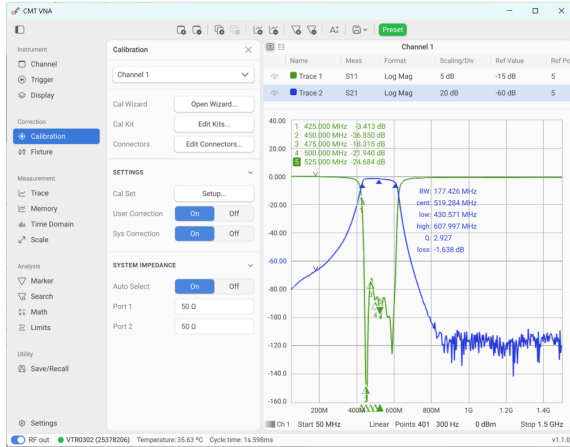

Two-level menu

Quick access toolbar

Hot keys

Calibration wizard

Kits and connectors libraries

Trace manager

Trace and marker math

Data analysis including markers and limit tests

Save/recall files and states, print

Automation

Free demo mode

The CMT VNA software can be downloaded free from our website, used on an unlimited number of PCs using either Linux or Windows operating systems, and enables easy analyzer integration with other software applications and automation. The software application features a fully functioning Demo Mode, which can be used for testing automation scripts and exploring the analyzers' features and capabilities without an actual measurement module connected to your PC.

Our software offers flexible options for controlling the analyzers. Users can configure parameters through a **two-level menu**, the **quick access toolbar**, the **channel status bar**, or by pressing **hotkeys**. The quick access toolbar can be customized to individual preferences, ensuring maximum efficiency and a personalized workflow.

Service

Accredited Calibration Labs



Periodic verification is used to check the instrument to ensure that it is operating within its specifications. Two years is recommended, but the interval should be determined by your organization's quality policy.

Our Indianapolis and Cyprus calibration laboratories are accredited in accordance with the recognized international standard ISO/IEC 17025 (2017) and meet the requirements of ANSI/NCSL Z540-1994-1.

Warranty, Service, & Repairs

All our products come with a standard three-year warranty from date of shipment. During that time we will repair or replace any product malfunctioning due to defective parts or labor.

While we pride ourselves on quality of our instruments, should your VNA malfunction for any reason, we will gladly offer a loaner unit while we service yours. With our USB VNAs where all data is stored on your PC, a simple swap of the measurement module assures uninterrupted workflow and little or no downtime.

The Crown Customer Service Package

The package includes support that goes beyond the analyzer. Our expert engineers give guidance to customers using CMT analyzers regarding their measurement setup, automation, and much more. This package provides an unparalleled level of service before, during, and after the purchase of the analyzer. And the best part? It's included with every purchase from every company. We are always here to provide reliable and timely customer support.

Automation Support

We understand that your time is valuable, which is why our team strives to provide rapid support for engineers using automation in their testing. Because we want to keep you working, our Crown Customer Service package includes help with setting up your testing automation for your analyzer. Our engineers have lots of experience with many coding languages, like C++, Python, MATLAB*, Visual Basic (Excel)*, and LabVIEW*.



Supporting Unique Applications

Technological advancements have engineers using analyzers for more things than ever before.

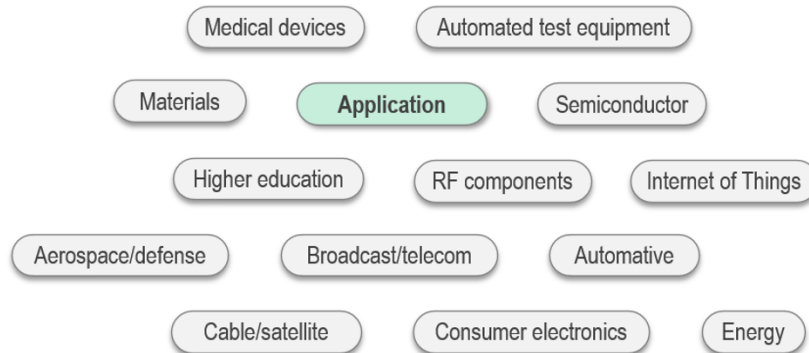

Customers are using CMT analyzers in industries such as agriculture, automotive R&D and manufacturing tests, medical applications, the expansive network of IoT and IIoT, energy, and more. Determining the ideal analyzer often requires extensive research, so the Crown Customer Support Package includes a consultation with our technical staff to discuss your specific application and recommend the best options. This support package comes at no charge with the purchase of a Copper Mountain Technologies VNA.

Having Issues with Your Analyzer?

We have built and supply high-quality test equipment we are proud of and stand behind. However, we know that issues happen, and when they do, we are here to help. Be it software support, repairs, or just a routine annual verification, the Crown Customer Service Package includes beyond-average rapid support for all of these occurrences. Our service and support teams do all they can to get the analyzer back to making accurate measurements as soon as possible.

For more detailed information, please visit our website:

<https://coppermountaintech.com/crown-customer-service-package/>

Standard Measurement Capabilities

Measurement Parameters

Data Display Formats

Logarithmic magnitude, linear magnitude, phase, expanded phase, group delay, SWR, real and imaginary parts, and polar diagram.

Number of Channels, Diagrams, and Traces

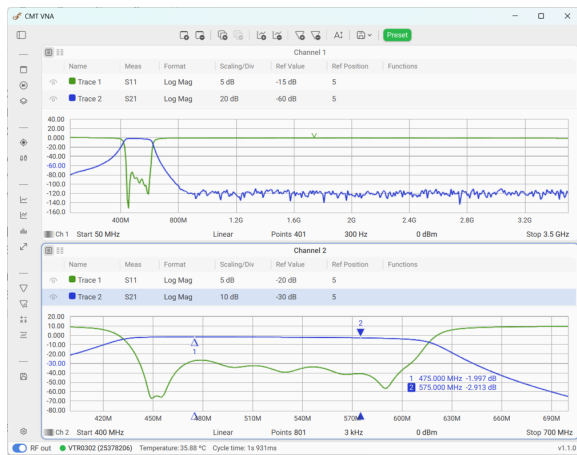

The software has no limitations on the number of channels, diagrams, or traces.

CMT VNA software allows users to create as many channels as needed, enabling precise customization of each measurement through individual channel settings and calibration.

A channel is considered to be a separate logical analyzer with its own unique settings.

Two Channels with Individual Settings

To facilitate working with the numerous available parameters, the table below presents the instrument settings grouped into two categories: channel and trace.

Channel settings	Sweep range, number of points, power level, CW frequency, segment sweep table, IF bandwidth, averaging, trigger mode, calibration, fixture simulator.
Trace settings	Measured parameter along with conversions, display format, scale settings, electrical delay, phase offset, memory trace, math operation, smoothing, time domain, markers with search and math functions, limit test, ripple limit test, peak limit test.

M5180 Value Series Vector Network Analyzer Specifications

The software features a zoom function that allows you to easily focus on and analyze a specific part of the diagram in more detail.

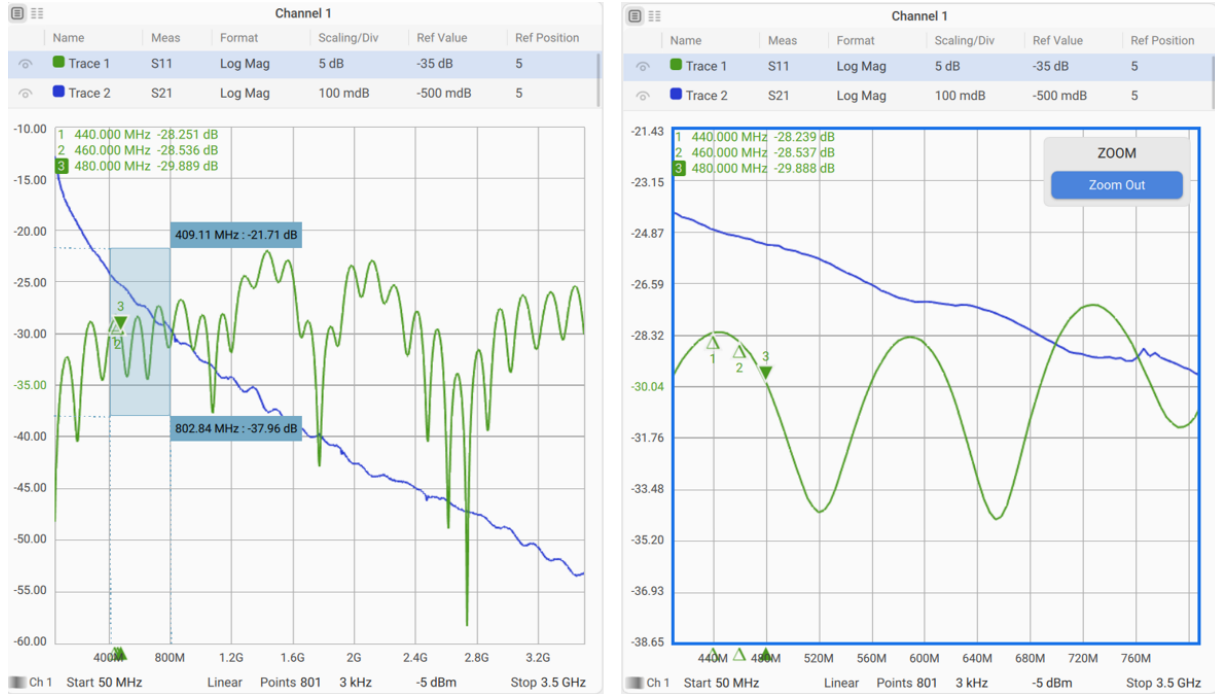

Software Capabilities

Sweep Features

Sweep type	Sweep range, number of points, power level, CW frequency, segment sweep table, IF bandwidth, averaging, trigger mode, calibration, fixture simulator.
Trigger	Measured parameter along with conversions, display format, scale settings, electrical delay, phase offset, memory trace, math operation, smoothing, time domain, markers with search and math functions, limit test, ripple limit test, peak limit test.

Segment Sweep

In applications where a continuous sweep may be undesirable, this function allows the user to sweep frequency segments rather than the entire frequency span. This can lead to faster measurement results.

A frequency sweep can be made within several independent user-defined segments.

Frequency range, number of sweep points, IF bandwidth, source power, and delay can be set for each segment.

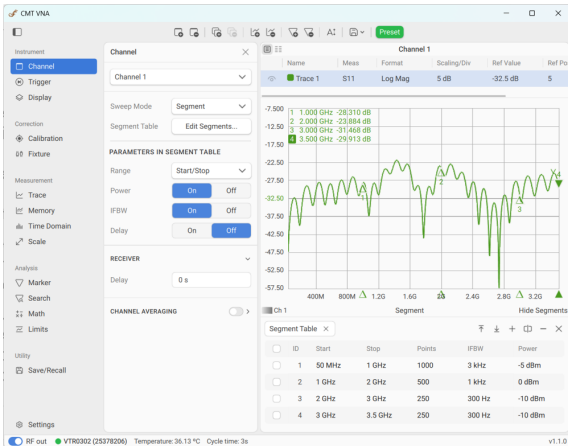

Segment Sweep Feature

Power Sweep

The power sweep feature enables users to perform compression point recognition, one of the most fundamental and complex amplifier measurements, in a simple manner.

In this case, you can use either S21 transmission or the test receiver power measurements.

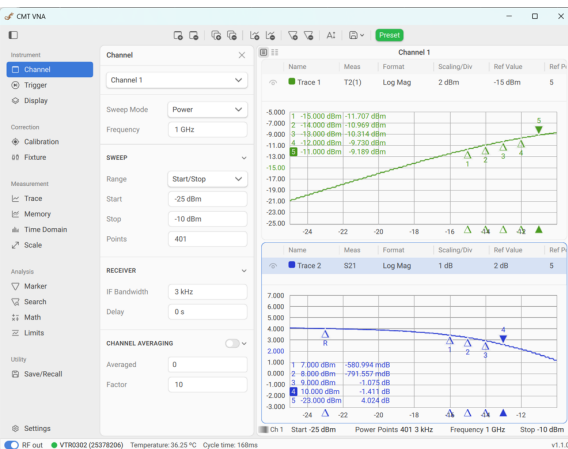

Power Sweep

Trace Functions

CMT VNA software incorporates many trace functions, such as:

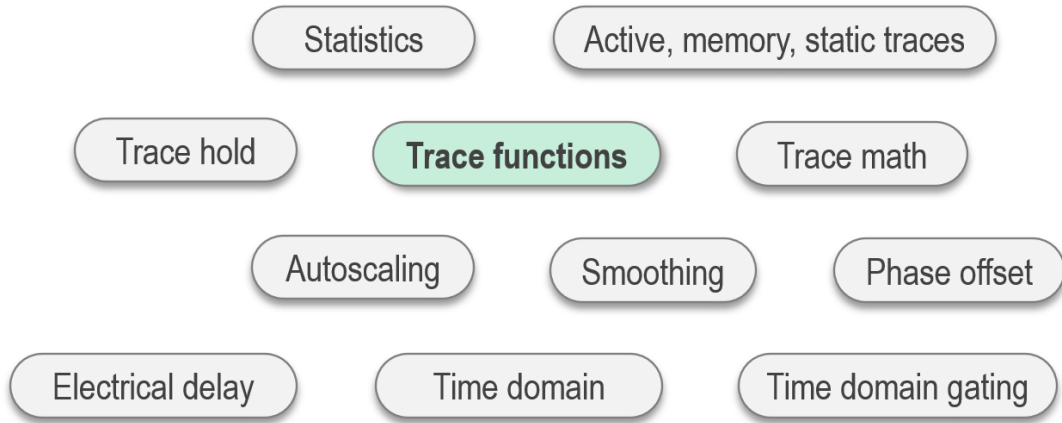

Traces	Data trace, memory trace, or simultaneous indication of data and memory traces.
Static trace	You can recall data from a file and perform any calculation using the full range of functions available in the software.
Trace math	Data trace modification by math operations: addition, subtraction, multiplication or division (normalization) of measured complex values and memory data.
Smoothing	Smoothing averages the adjacent points of the trace by the moving window. Smoothing helps to reduce trace noises. Smoothing is set for each trace independently.
Statistics	The trace statistics feature allows to determine and view trace parameters, such as mean, standard deviation, and peak-to-peak. The range of trace statistics can be defined by two markers or band.
Trace hold	The trace hold function is used to hold the maximum or minimum values of the trace.
Autoscaling	Automatic selection of scale division and reference level value to have the trace most effectively displayed.
Electrical delay	The electrical delay function compensates for the delay of the trace measurement. This function is useful during measurements of phase deviations from linear.
Phase offset	The function applies a chosen constant phase offset to S-parameter measurements at all frequencies.

Time Domain Measurements

This function performs conversion of the DUT response from frequency domain to time domain.

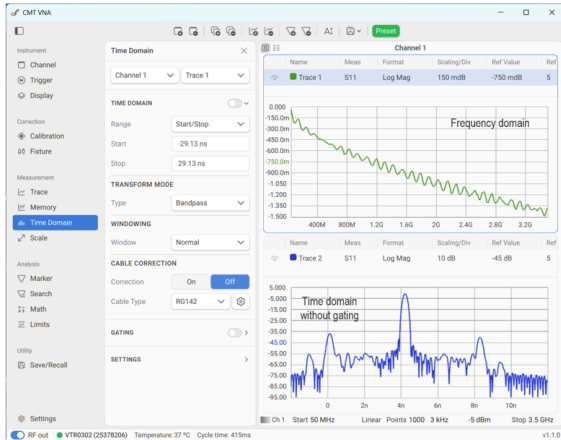

Modeled time domain stimulus types are bandpass, lowpass impulse, and lowpass step.

The time domain span is determined by the frequency span and the number of measurement points.

Windowing functions of various shapes are used for tradeoff between resolution and levels of spurious sidelobes.

Cable Measurement with Open at the End

Time Domain Gating

This function mathematically removes unwanted responses in the time domain, allowing the user to obtain a frequency response without the effects of fixture elements.

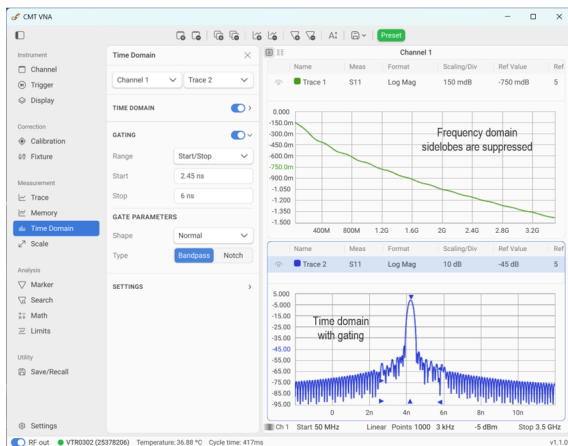

Reflections occurring within a chosen time span may be bandpass gated such that all other reflections are suppressed or notch gated such that reflections in the chosen time span are suppressed.

After time domain gating, the result with chosen reflections removed may be viewed in the frequency domain. Gating filter types are bandpass or notch. For a better tradeoff between gate resolution and level of spurious sidelobes the following filter shapes are available: maximum, wide, normal and minimum.

Cable Measurement with Open at the End

Data Analysis

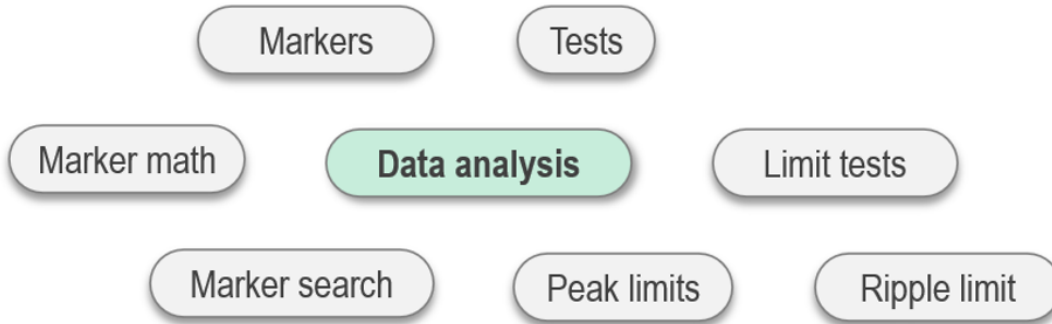

Markers	Marker tools are used to read and look up the numerical values of the stimulus and the measured value on selected points on the graph. The software has no limitations on the number of markers.
Marker search	The marker position search function allows the user to find the following values on a trace: maximum value, minimum value, peak value, target level.
Marker math	Marker math functions use markers to calculate various trace characteristics: trace statistics, bandwidth/notch search, flatness evaluation, RF filter statistics.
Limit tests	The limit test is a function of automatic pass/fail judgment for the trace of the measurement result.
Ripple limit	The ripple limit test is an automatic pass/fail check of the measured trace data. The trace is checked against the maximum ripple value. The ripple value is the difference between the maximum and minimum response of the trace in the trace frequency band.
Peak limits	The peak limits test function checks whether the trace point with the minimum or maximum value of the measured value falls within the specified limits of the frequency range and/or value range.

Limit Testing

Limit testing is a function that provides automatic pass/fail evaluation based on measurement results. The trace is compared against a user-defined limit line, which may consist of one or multiple segments. This function allows users to quickly verify compliance with specified requirements by comparing measurement traces against predefined thresholds. This ensures efficient quality control, accelerates testing, and reduces the risk of overlooking deviations from specifications.

Each segment verifies whether the measurement value exceeds the upper limit, falls below the lower limit, or both. A limit line segment is defined by specifying the start coordinates (X0, Y0) and stop coordinates (X1, Y1), along with the limit type. The MAX and MIN limit types check whether the trace re-mains below or above the defined limit line, respectively.

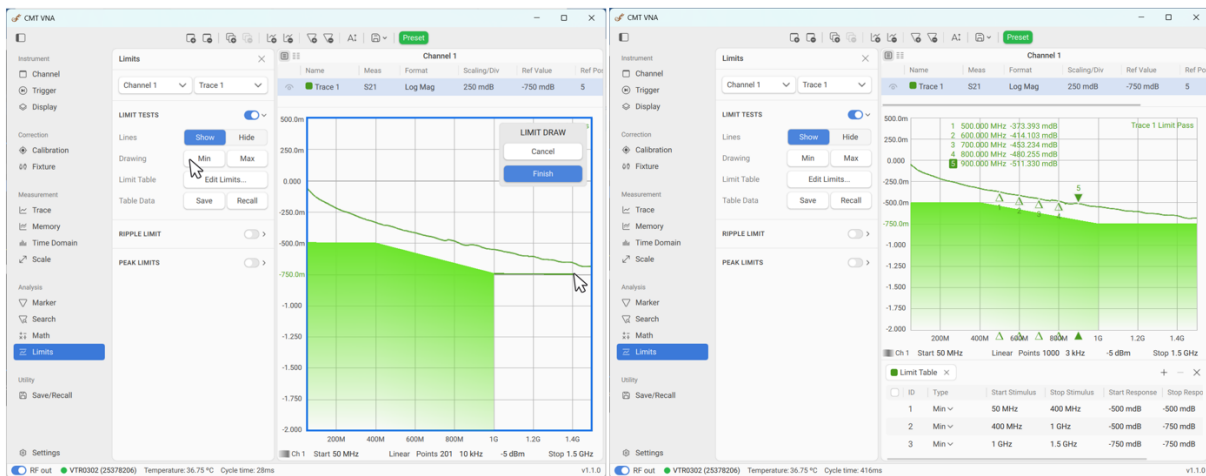

Limit lines can be created either interactively using the mouse or by entering values directly into the limit table. The limit line can be drawn in with more than two points. Alternatively, choose the limit table button and enter the limit line values.

Calibration

Calibration can be done using the new **Basic calibration wizard**, which allows for easy and intuitive calibration using enabled calibration kits.

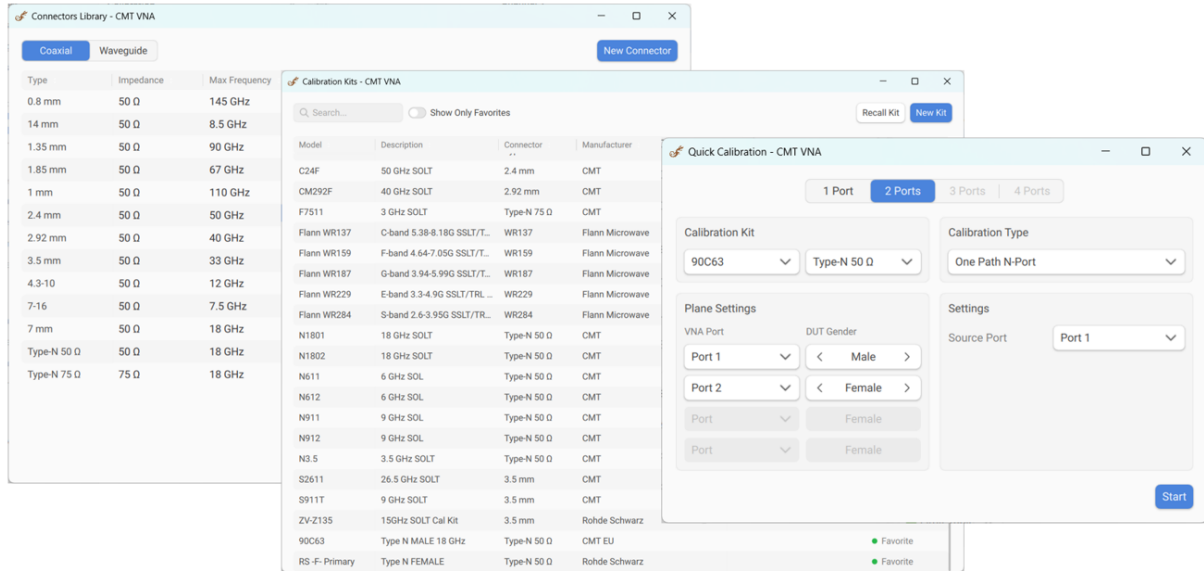

M5180 Value Series Vector Network Analyzer Specifications

Calibration wizard	The basic calibration wizard is a simple and intuitive tool for performing analyzer calibration. It guides the user through the calibration process, indicating which standards need to be connected and how many steps are required.
Calibration methods	The following calibration methods of various sophistication and accuracy are available: reflection (open, short, both open and short) and transmission response, full 1-port calibration, 1-path 2-port calibration.
Error correction interpolation	Interpolation or extrapolation of the calibration coefficients will be applied when the user changes any settings such as the start/stop frequencies or the number of sweep points, compared to the settings at the moment of calibration. Extrapolation is not recommended for accurate measurements.
Kit library	This library stores definitions of calibration kits, both predefined and user-created. A search function can be used to locate the required definition. Definitions can be saved to a file and later used at different workstations. Definitions marked as "Favorite" will appear first in the list of available kits during calibration.
Calibration standard definition	Different methods of calibration standard definition are available: standard definition by polynomial model and standard definition by Touchstone data file (S-parameters).
Connector library	This library is designed to store connectors, categorized into coaxial and waveguide types. By default, the library contains a comprehensive set of standardized connectors.

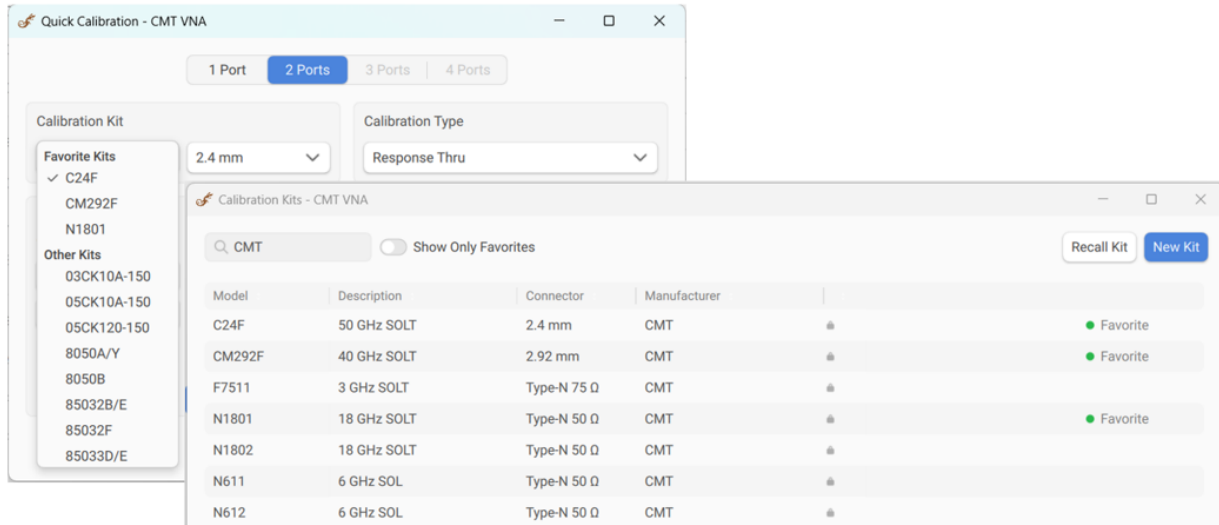

Kit Library with "Favorites" Marked

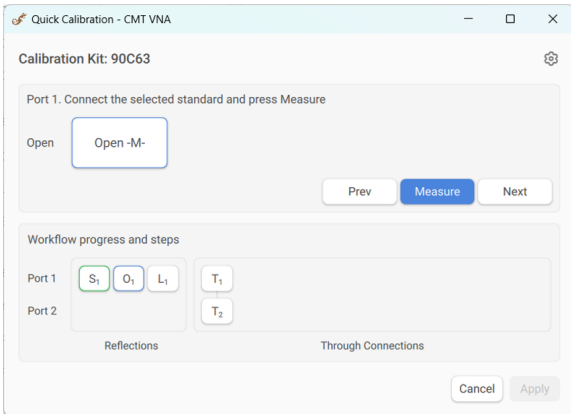

Basic Calibration Wizard

Calibration of a test setup (which includes the analyzers, cables, and adapters) significantly increases the accuracy of measurements.

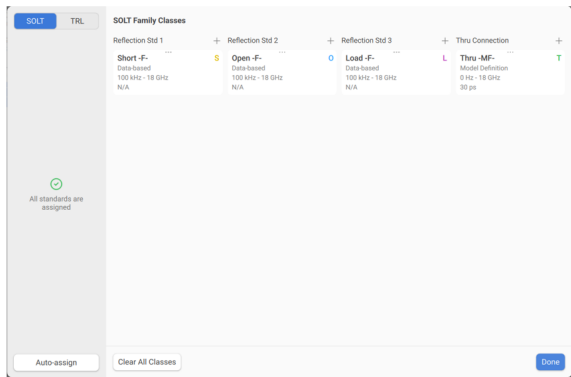

Creating the Kit Definition and Class Assignment

The software allows for class assignment to be done automatically to simplify user kit creation. The assignment is carried out after adding a new standard and selecting its type.

The standards are arranged in a sequence that makes it easy to identify which type of calibration they support. For example, in the figure, the letters SOLT are clearly visible, indicating that the Short, Open, Load, and Thru standards will need to be connected during calibration.

Fixture

This section includes a set of functions that either modify the position of the calibration plane or recalculate the scattering matrix parameters.

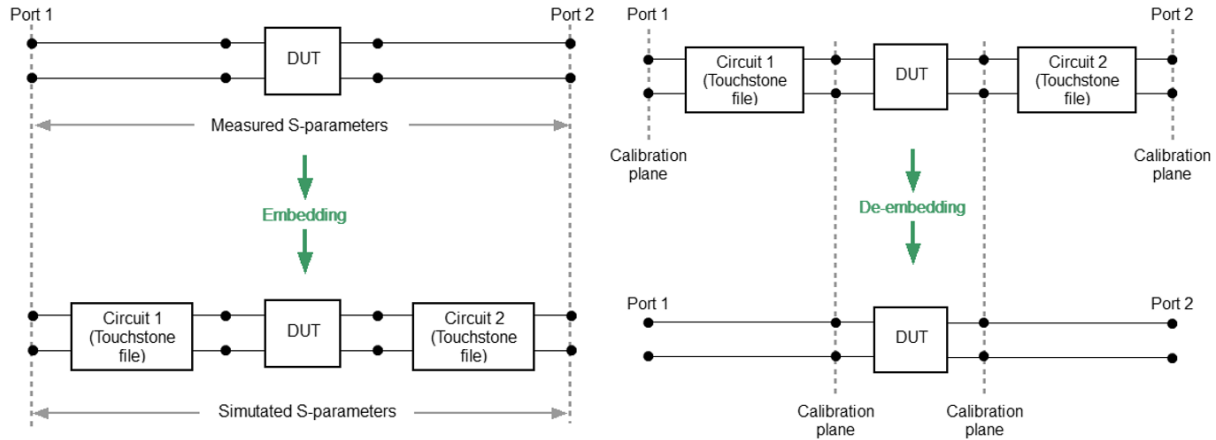

<p>Embedding</p>	<p>Embedding is a function of the S-parameter transformation via integration of some virtual circuit into the real network. The function allows the user to mathematically simulate the DUT parameters after adding the fixture circuits.</p>
<p>De-embedding</p>	<p>De-embedding is a function of transforming the S-parameter by eliminating some circuit effect from the measurement results. The function allows the user to mathematically exclude the effect of the fixture circuit existing between the calibration plane and the DUT in the real network from the measurement results.</p>
<p>Port impedance conversion</p>	<p>Port reference impedance conversion is a function that mathematically converts the matrix of S-parameters measured at the reference impedance of port Z_0 to the matrix of S-parameters measured at an arbitrary impedance of port Z_1.</p>

Data Output

Analyzer state	All state, calibration and measurement data can be saved to a state file on the hard disk and later recalled into the software. The software supports the Quick Save to List function for storing analyzer settings and quickly switching between saved configurations.
Touchstone files	This selection allows users to save S-parameters to a Touchstone file, which contains frequency values along with the corresponding S-parameters. Touchstone files are an industry-standard format supported by most circuit simulation programs. The .s2p files are used to store all S-parameters of a device, while .s1p files are used to store either the S11 or S22 parameter of a one-port device. Additionally, the software can function as a Touchstone file viewer, enabling users to graphically display and analyze previously saved Touchstone files.
CSV files	This selection allows users to save an individual trace's data as a CSV file (comma separated values).

Screenshot capture



COPPER MOUNTAIN
TECHNOLOGIES

MEASUREMENT REPORT

Device under test: Cable measurements
 Vector network analyzer: VTR0302
 Location: Copper Mountain Technologies EU LTD

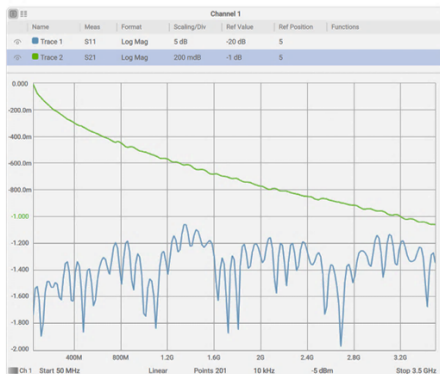

Template of a Report Generated by
CMT VNA Software

Screenshots can be printed using three different applications: MS Word, Image viewer for Windows, or the Print wizard.

Each screenshot can be printed in color, grayscale, or inverted for visibility or to save ink.

The current date and time can be added to each capture before it is transferred to the printing application, resulting in quick and easy test reporting.

A Word template file can be customized to change the appearance of the MS Word file output.

This function enables users to save measurement data in accordance with a predefined template, with the capability to incorporate supplementary information regarding the operator, the device under test (DUT), and the experimental conditions.

Automation

We maintain code examples and guides in the following languages:

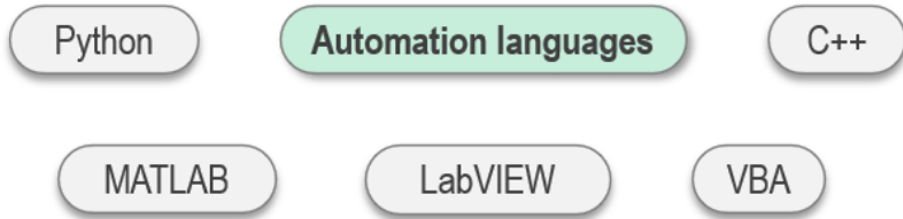

SCPI via TCP Socket

Alternatively a TCP socket is provided for automation from either localhost - the same machine running the analyzer software application - or from a second PC connected by an IP network. The SCPI commands are largely compatible with legacy instruments, maximizing code reuse for existing test automation platforms

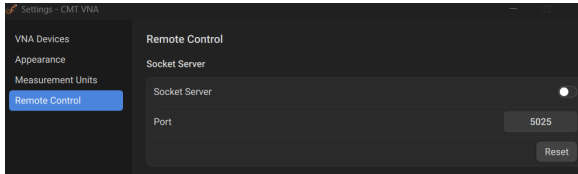

Remote Control in the Settings

SCPI via TCP Socket can be used with either Windows or Linux operating systems.

LabVIEW Compatible

The instrument and its software are fully compatible with LabVIEW applications, for ultimate flexibility in user-generated programming and automation. LabVIEW can be used with Windows OS only.

Hardware Specifications

Value Series M5180

Measurement Range

Impedance	50 Ohm
Test port connector	type N, female
Number of test ports	2
Frequency range	300 kHz to 18 GHz
Full frequency accuracy	$\pm 5 \cdot 10^{-6}$
Frequency resolution	1 Hz
Number of measurement points	2 to 500,001
Measurement bandwidths (with 1/1.5/2/3/5/7 steps)	1 Hz to 300 kHz
Dynamic range²	
300 kHz to 1 MHz	100 dB
1 MHz to 6.5 GHz	130 dB
6.5 GHz to 12 GHz	125 dB
12 GHz to 16 GHz	122 dB
16 GHz to 18 GHz	118 dB
Crosstalk^{2a}	
300 kHz to 5 GHz	-
5 GHz to 7.5 GHz	-120 dB typ.
7.5 GHz to 8.5 GHz	-110 dB typ.
8.5 GHz to 15 GHz	-120 dB typ.
15 GHz to 18 GHz	-100 dB typ.

[2] The dynamic range is defined as the difference between the specified maximum power level and the specified noise floor. The specification applies at 10 Hz IF bandwidth.

[2a] Uncorrected crosstalk is defined at maximum specified output power level. Dynamic range of the analyzer may be limited on the lower end by either crosstalk or noise floor.

Measurement Accuracy^[3]

Accuracy of transmission measurements ⁴	Magnitude/Phase
300 kHz to 1 MHz	
0 dB to +10 dB	± 0.2 dB / $\pm 2^\circ$
-30 dB to 0 dB	± 0.1 dB / $\pm 1^\circ$
-50 dB to -30 dB	± 0.2 dB / $\pm 2^\circ$
-70 dB to -50 dB	± 1.0 dB / $\pm 6^\circ$
1 MHz to 6.5 GHz	
0 dB to +10 dB	± 0.2 dB / $\pm 2^\circ$
-60 dB to 0 dB	± 0.1 dB / $\pm 1^\circ$
-80 dB to -60 dB	± 0.2 dB / $\pm 2^\circ$
-100 dB to -80 dB	± 1.0 dB / $\pm 6^\circ$
6.5 GHz to 12 GHz	
0 dB to +10 dB	± 0.2 dB / $\pm 2^\circ$
-55 dB to 0 dB	± 0.1 dB / $\pm 1^\circ$
-75 dB to -55 dB	± 0.2 dB / $\pm 2^\circ$
-95 dB to -75 dB	± 1.0 dB / $\pm 6^\circ$
12 GHz to 16 GHz	
0 dB to +10 dB	± 0.2 dB / $\pm 2^\circ$
-50 dB to 0 dB	± 0.1 dB / $\pm 1^\circ$
-70 dB to -50 dB	± 0.2 dB / $\pm 2^\circ$
-92 dB to -70 dB	± 1.0 dB / $\pm 6^\circ$
16 GHz to 18 GHz	
0 dB to +6 dB	± 0.2 dB / $\pm 2^\circ$
-50 dB to 0 dB	± 0.1 dB / $\pm 1^\circ$
-70 dB to -50 dB	± 0.2 dB / $\pm 2^\circ$
-92 dB to -70 dB	± 1.0 dB / $\pm 6^\circ$

Accuracy of reflection measurements ⁵	Magnitude/Phase
300 kHz to 10 GHz	
-15 dB to 0 dB	±0.4 dB / ±3°
-25 dB to -15 dB	±1.0 dB / ±6°
-35 dB to -25 dB	±3.0 dB / ±20°
10 GHz to 18 GHz	
-15 dB to 0 dB	±0.5 dB / ±4°
-25 dB to -15 dB	±1.5 dB / ±10°
-35 dB to -25 dB	±5.5 dB / ±30°
Trace noise magnitude (IF bandwidth 3 kHz)	
300 kHz to 1 MHz	0.010 dB rms
1 MHz to 6.5 GHz	0.002 dB rms
6.5 GHz to 12 GHz	0.003 dB rms
12 GHz to 18 GHz	0.004 dB rms
Temperature dependence	
300 kHz to 6.5 GHz	0.02 dB/°C
6.5 GHz to 18 GHz	0.04 dB/°C

[3] Reflection and transmission measurement accuracy applies over the temperature range of (73 ± 9) °F or (23 ± 5) °C after 30 minutes of warming up, with less than 1°C deviation from the full two-port calibration temperature, at output power of -5 dBm. Frequency points have to be identical for measurement and calibration (no interpolation allowed).

[4] Transmission specification are based on a matched DUT, and IF bandwidth of 1 Hz.

[5] Reflection specifications are based on an isolating DUT.

Effective System Data

300 kHz to 10 GHz	
Directivity	46 dB
Source match	40 dB
Load match	46 dB
Reflection tracking	±0.10 dB
Transmission tracking	±0.08 dB
10 GHz to 18 GHz	
Directivity	42 dB
Source match	38 dB
Load match	42 dB
Reflection tracking	±0.10 dB
Transmission tracking	±0.08 dB

Uncorrected System Performance

300 kHz to 1 MHz	
Directivity	10 dB
Source match	8 dB
Load match	12 dB
1 MHz to 6.5 GHz	
Directivity	15 dB
Source match	12 dB
Load match	15 dB
6.5 GHz to 12 GHz	
Directivity	10 dB
Source match	8 dB
Load match	10 dB
12 GHz to 18 GHz	
Directivity	10 dB
Source match	8 dB
Load match	10 dB

Test Port Output

Power range	
300 kHz to 16 GHz	-45 dBm to +10 dBm
16 GHz to 18 GHz	-45 dBm to +6 dBm
Power accuracy*	±2 dB
Power resolution	0.05 dB
Harmonic distortion^[6]	-15 dBc
Non-harmonic spurious^[6]	
300 kHz to 16 GHz	-20 dBc
16 GHz to 18 GHz	-15 dBc

[*] Power accuracy applies over temperature range from 18°C to 28°C.

[6] Specification applies over frequency range above 10 MHz, at output power of 0 dBm.

Test Port Input

Noise floor	
300 kHz to 1 MHz	-100 dBm/Hz
1 MHz to 6.5 GHz	-130 dBm/Hz
6.5 GHz to 12 GHz	-125 dBm/Hz
12 GHz to 18 GHz	-122 dBm/Hz
Damage level	+23 dBm
Damage DC voltage	25 V

Measurement Speed

Time per point	30 µs typ.
Port switchover time	0.2 ms

Frequency Reference Input

Port	10 MHz Ref In/Out
External reference frequency	10 MHz
Input level	-1 dBm to 5 dBm
Input impedance	50 Ohm
Connector type	BNC, female

Frequency Reference Output

Port	10 MHz Ref In/Out
Internal reference frequency	10 MHz
Output reference signal level at 50 Ohm impedance	-1 dBm to 5 dBm
Connector type	BNC, female

Trigger Input

Port	Ext Trig In
Input level	
Low threshold voltage	0.5 V
High threshold voltage	2.7 V
Input level range	0 V to +5 V
Pulse width	$\geq 2 \mu\text{s}$
Polarity	positive or negative
Input impedance	$\geq 10 \text{ k}\Omega$
Connector type	BNC, female

Trigger Output

Port	Ext Trig Out
Maximum output current	20 mA
Output level	
Low level voltage	0.0 V
High level voltage	3.5 V
Polarity	positive or negative
Connector type	BNC, female

System and Power

S2VNA Software	
Operating system (min requirements)	Windows 10 and above
CPU	4 core 2.0 GHz (x64)
RAM	4 GB
CMT VNA Software	
Operating system (min requirements)	Windows 10, Ubuntu 24.04
CPU	4 core 2.0 GHz (x64 or arm64)
RAM	8 GB
Interface	USB 2.0
Connector type	USB C
Input power (VNA)	11 V DC to 15 V DC
Input power consumption (VNA)	35 W
Power supply (Main outlet)	110-240 V, 50/60 Hz
Power consumption (Main outlet)	40 W

Calibration

Recommended factory adjustment interval	3 years
--	---------

Dimensions

Length	370 mm
Width	210 mm
Height	75 mm
Weight	3.9 kg (137.5 oz)

Environmental Specifications

Operating condition	
Temperature	+5 °C to +40 °C (41 °F to 104 °F)
Humidity	90 % at 25 °C (77 °F)
Storage	
Temperature	+0 °C to +40 °C (32 °F to 104 °F)
Humidity	80 % at 35 °C (95 °F)
Non-operating temperature	-50 °C to +70 °C (-58 °F to 158 °F)
Atmospheric pressure	70.0 kPa to 106.7 kPa

Reflection Accuracy Plots

Reflection Magnitude Errors

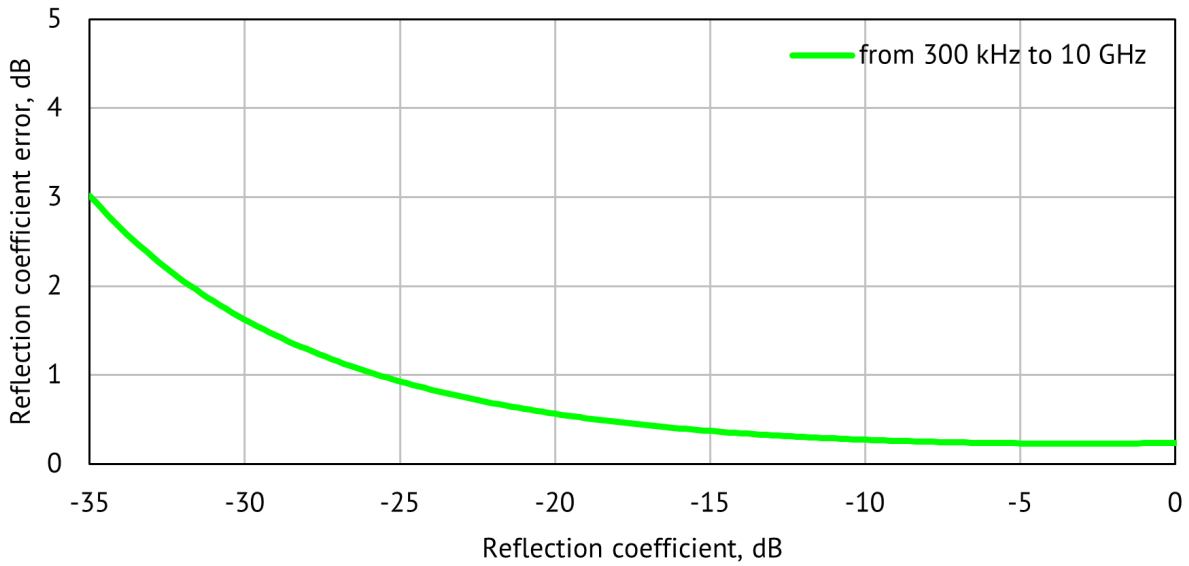
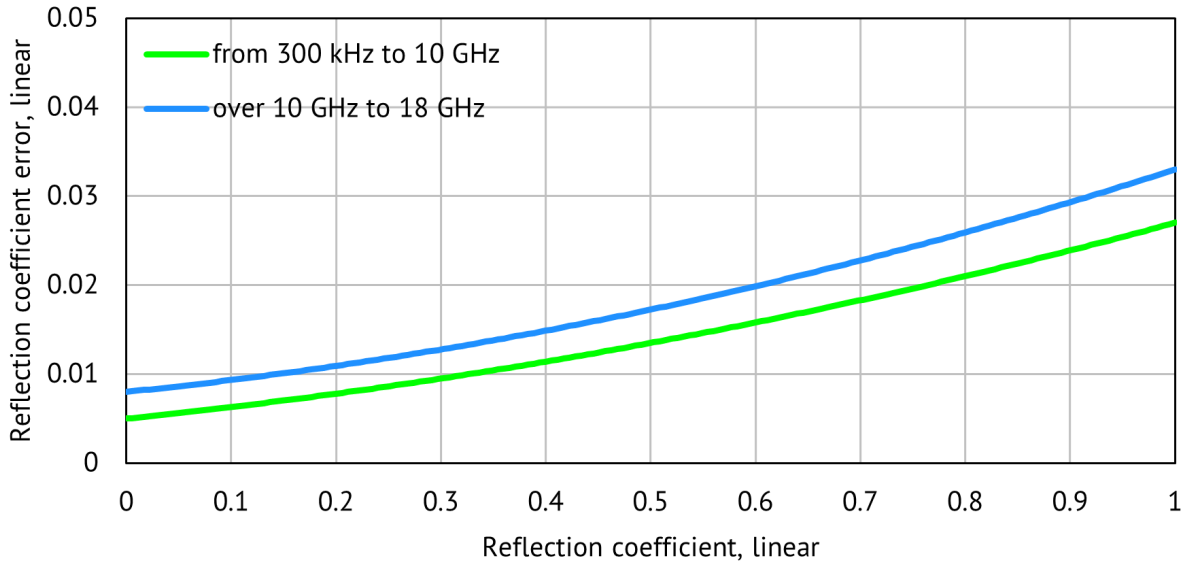

M5180 Value Series Vector Network Analyzer Specifications

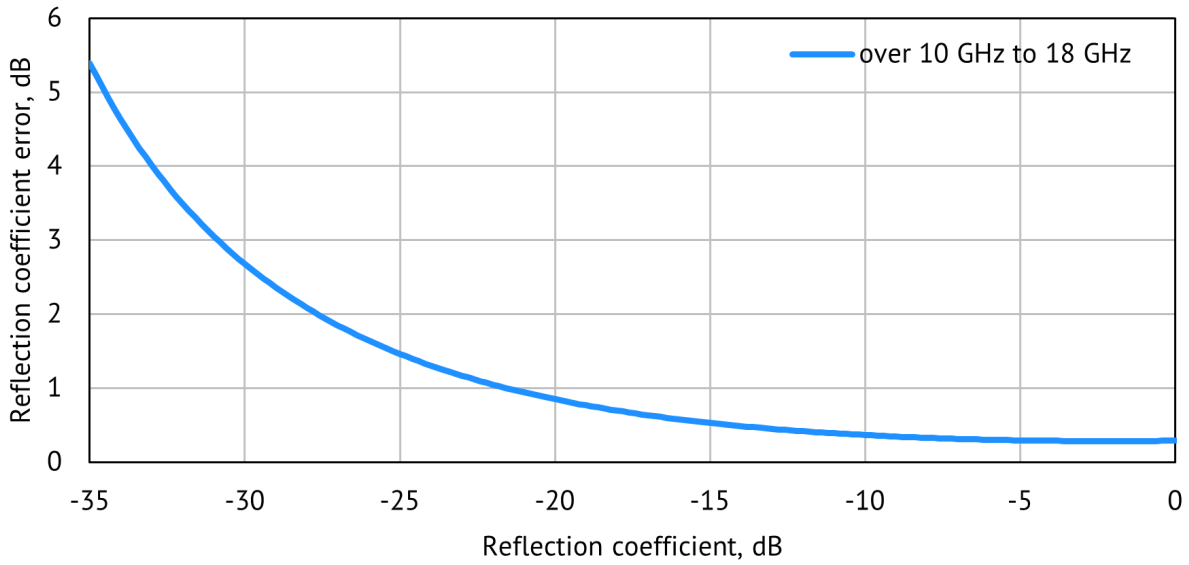

Specifications are based on an isolating DUT ($S_{21} = S_{12} = 0$)

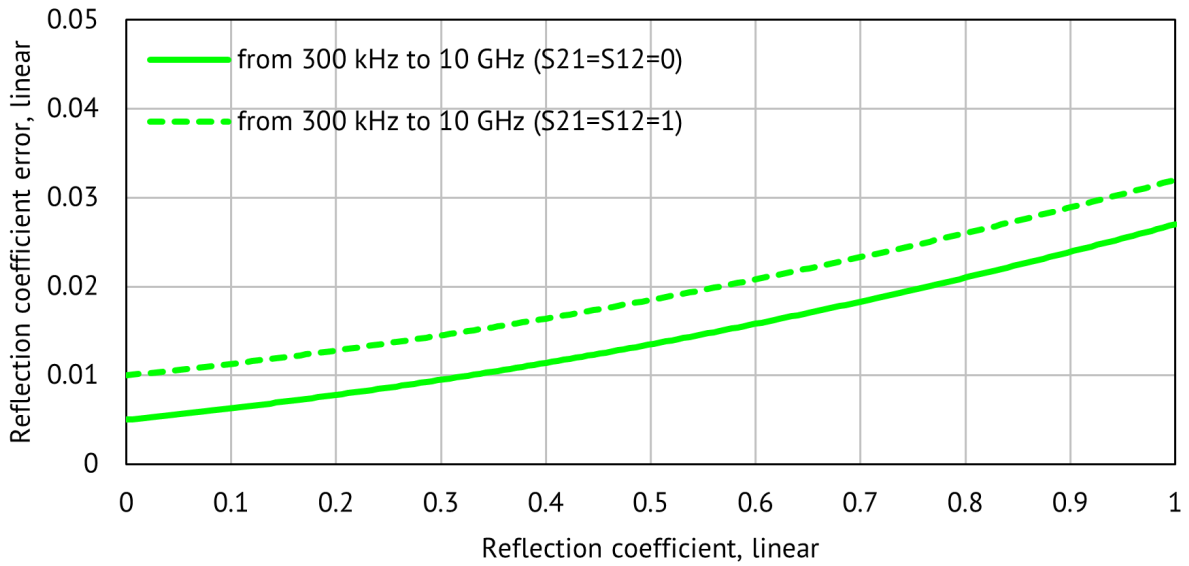

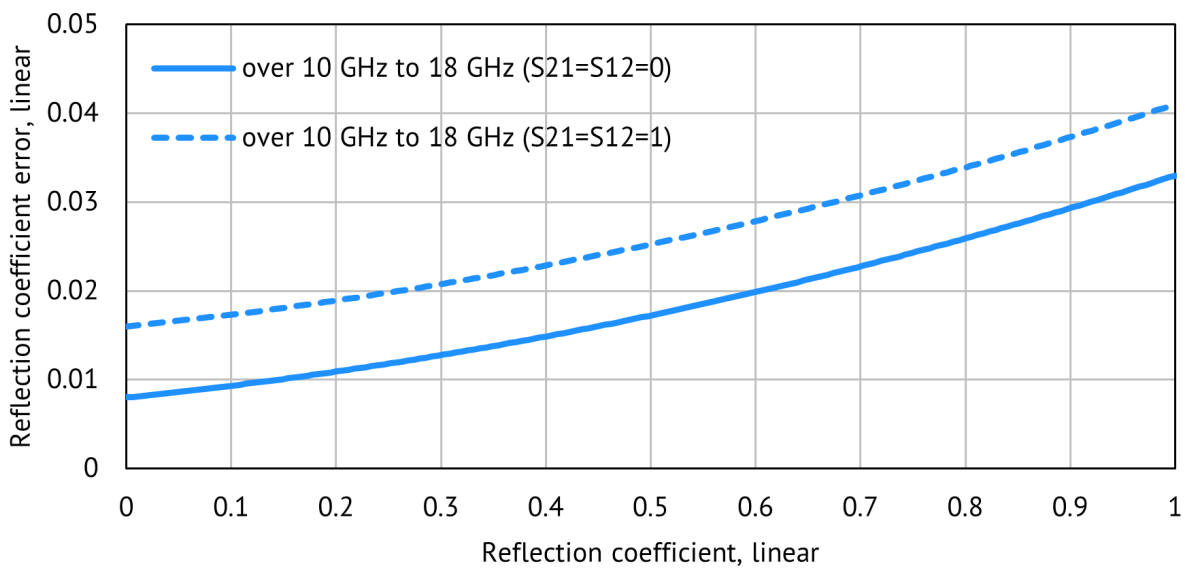

Reflection Phase Errors

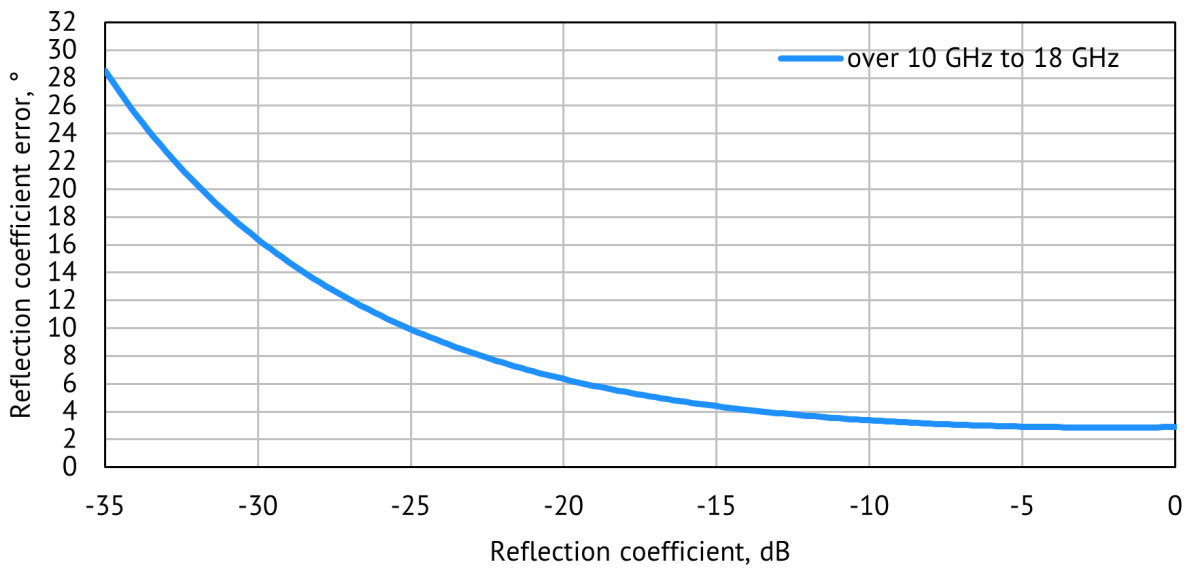
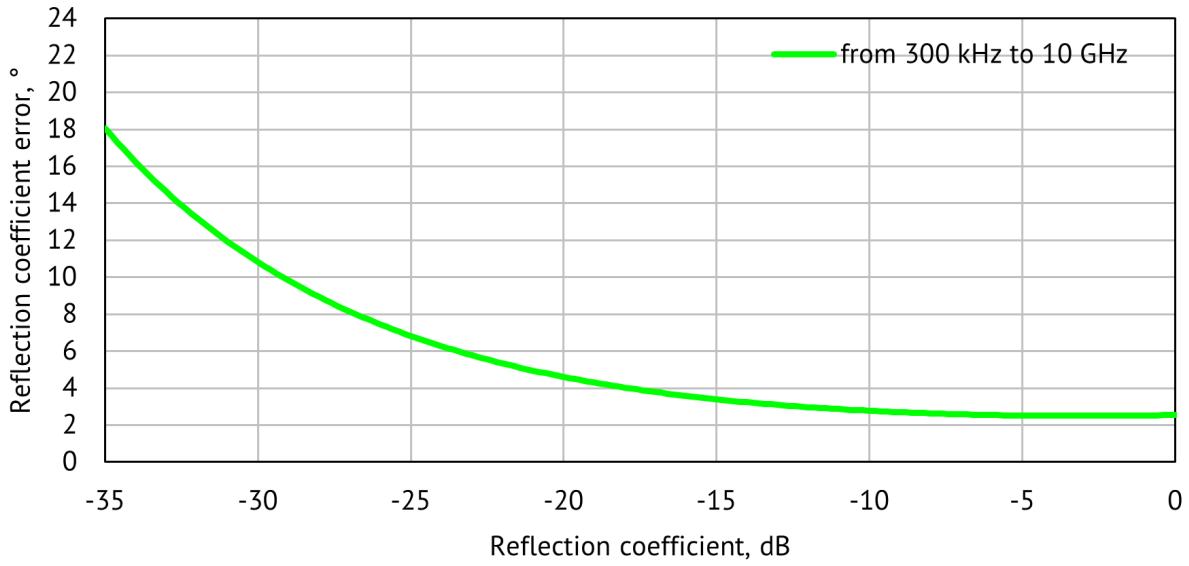

Specifications are based on isolating DUT ($S_{21} = S_{12} = 0$)

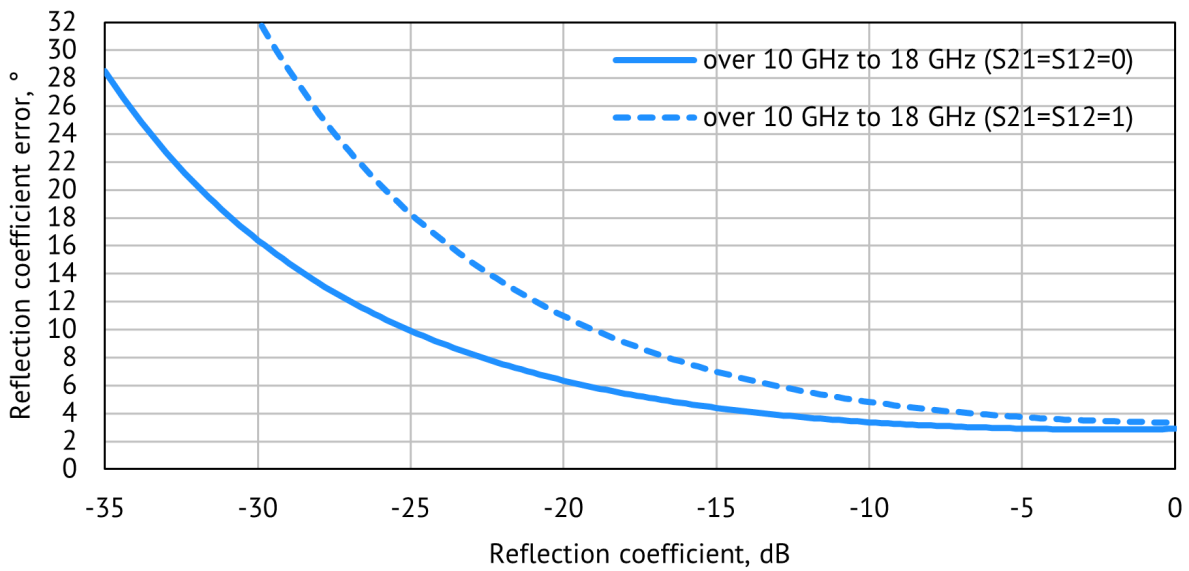
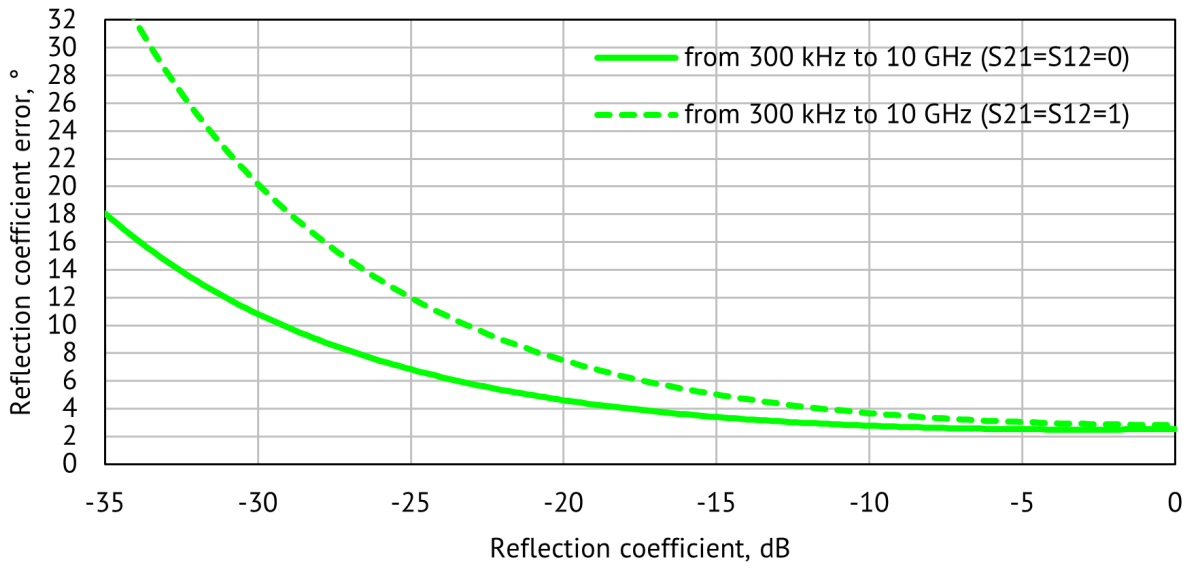

Transmission Accuracy Plots

Transmission Magnitude Errors

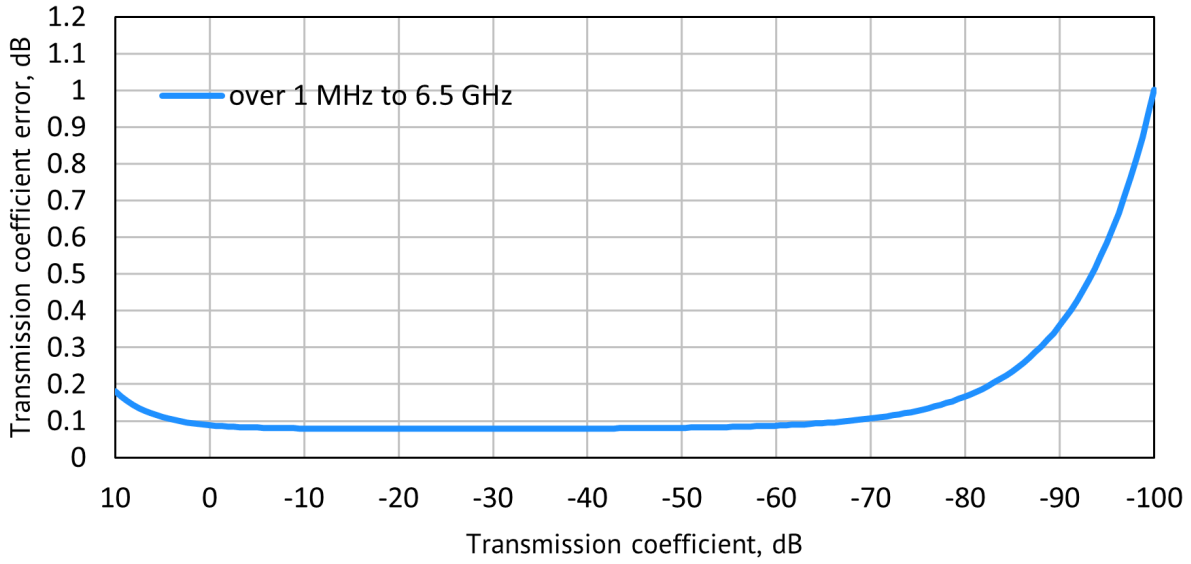
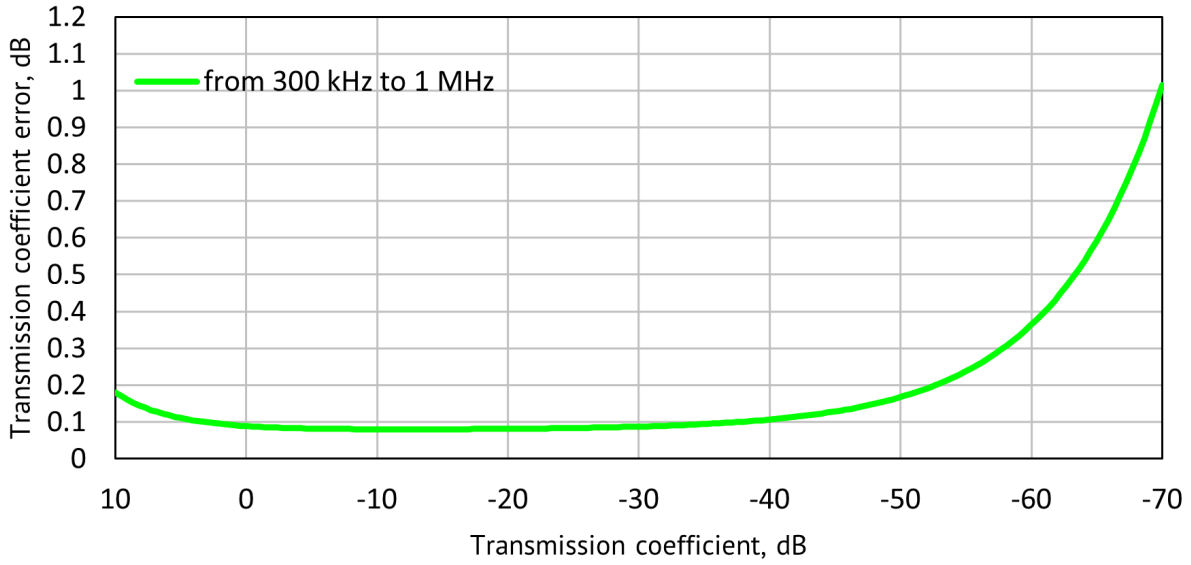

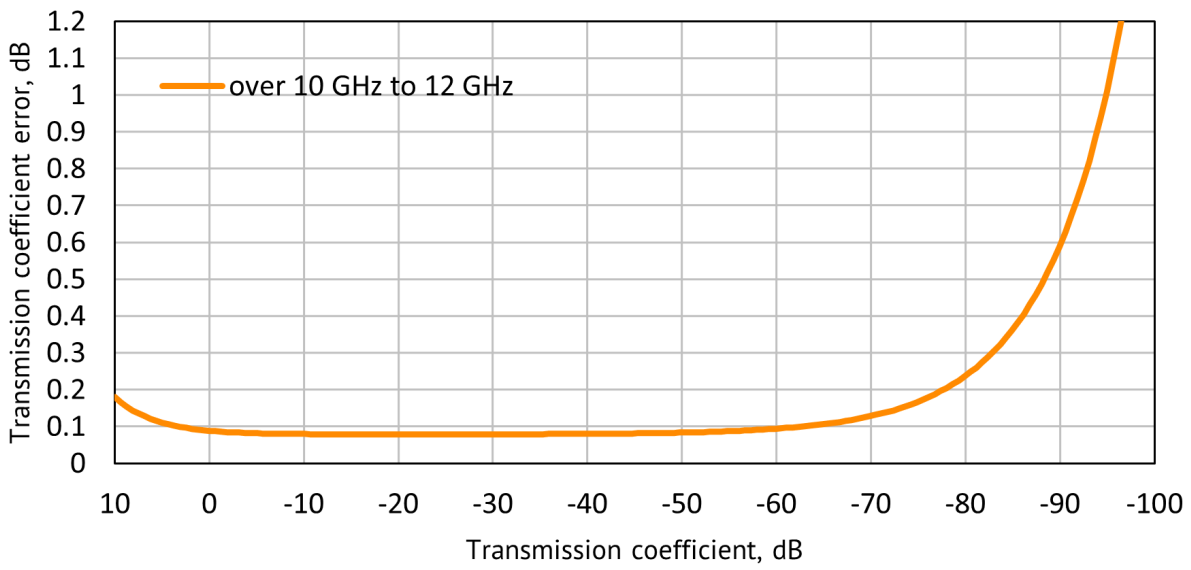
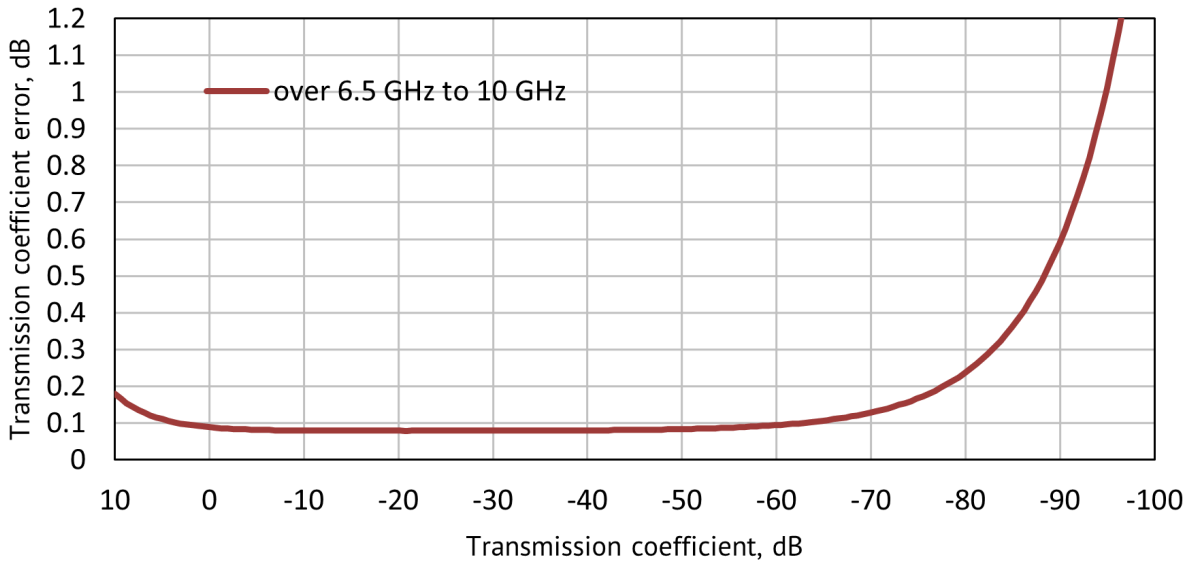

M5180 Value Series Vector Network Analyzer Specifications

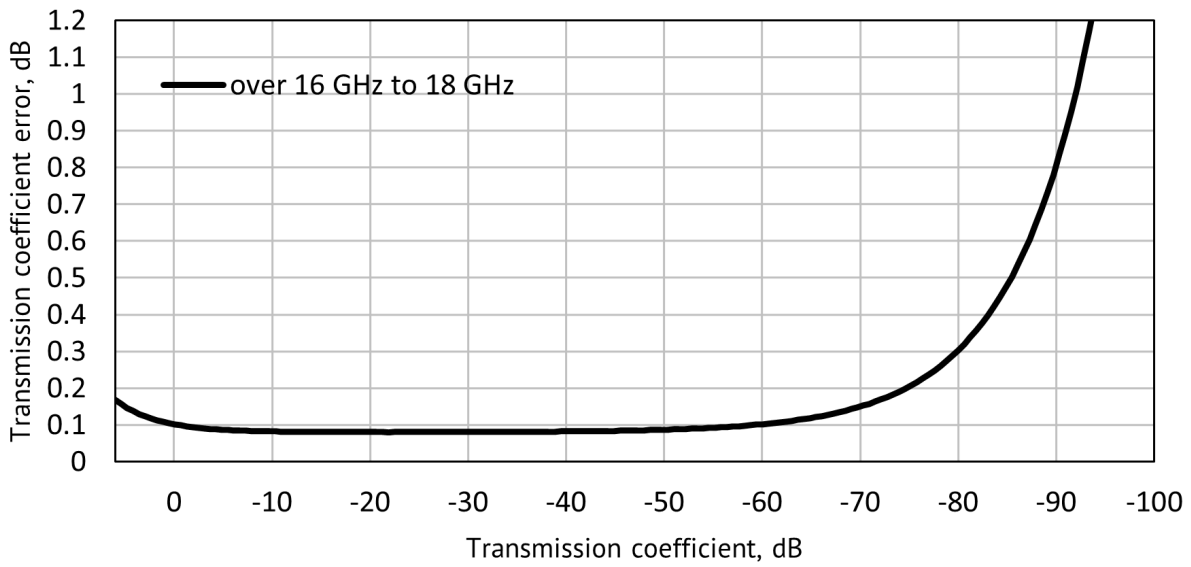
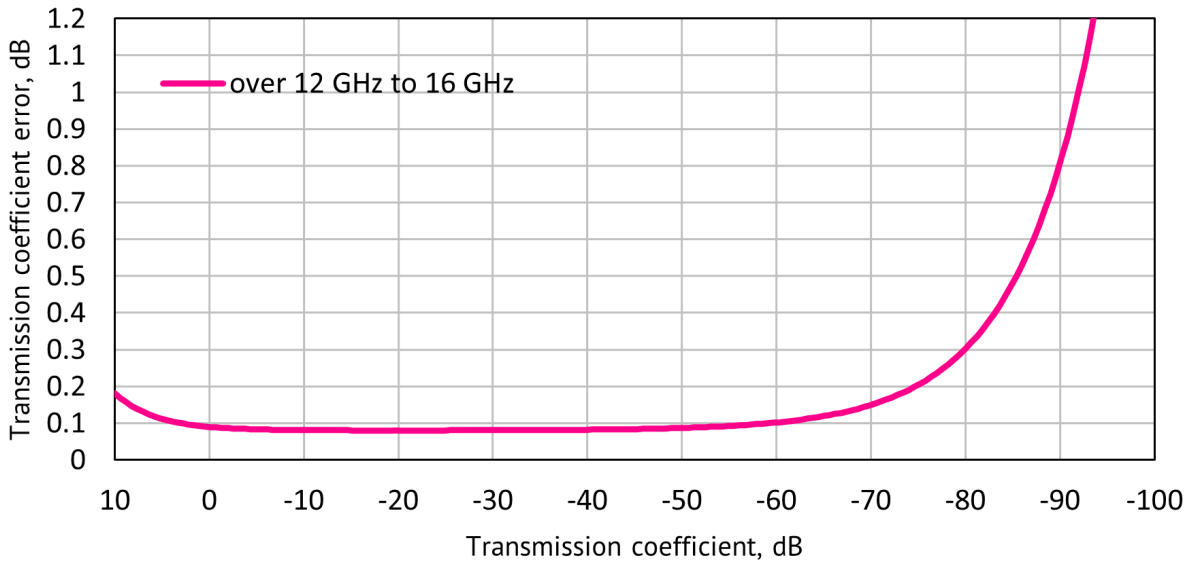

Specifications are based on matched DUT, and IF bandwidth of 1 Hz

Transmission Phase Errors

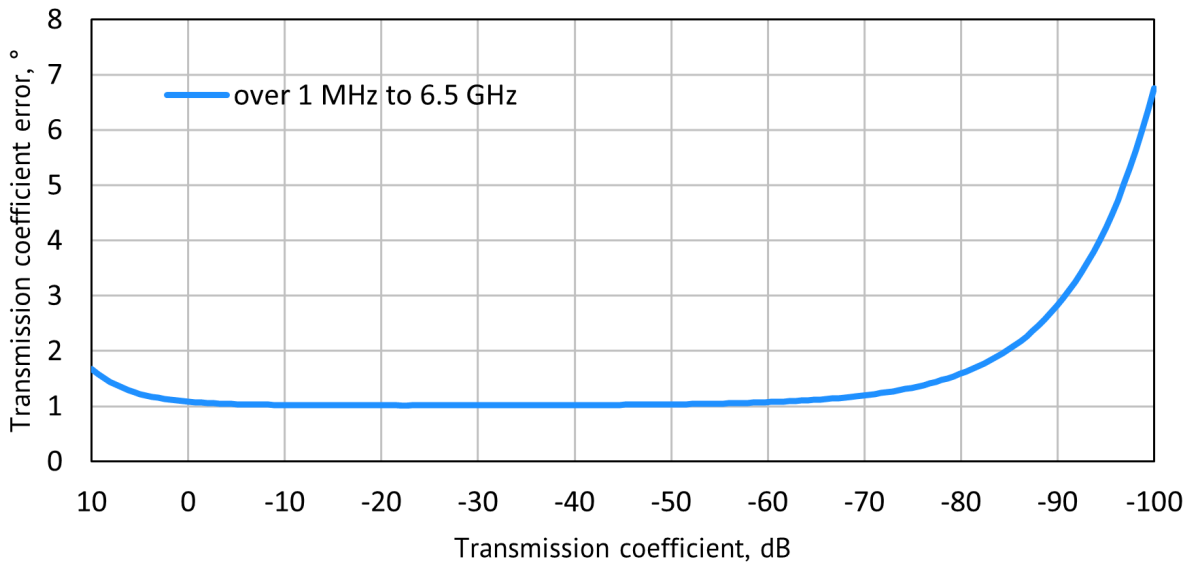
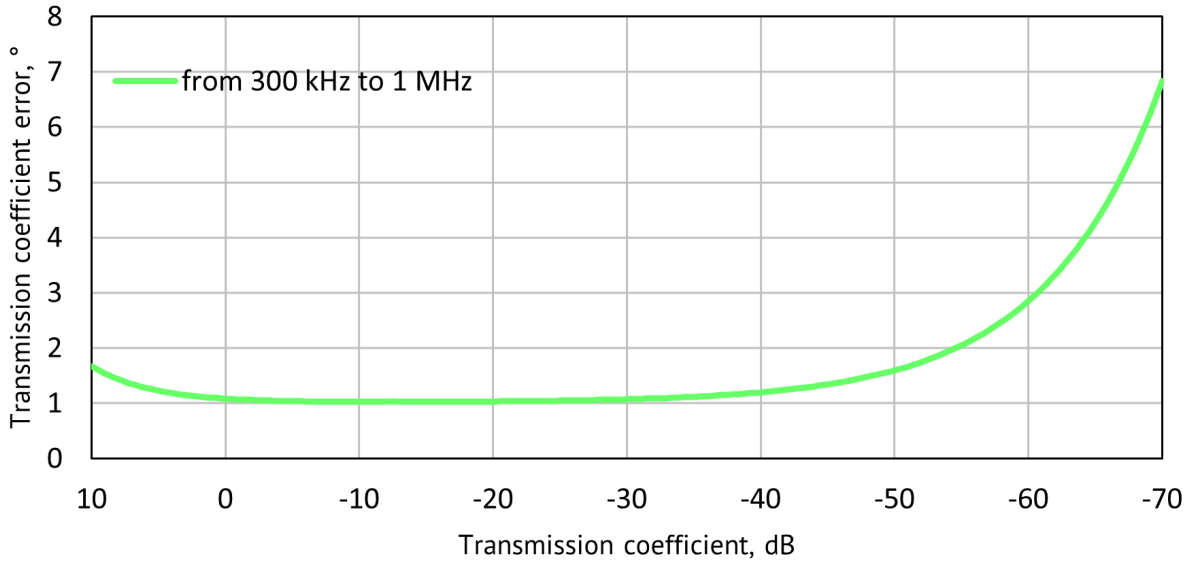

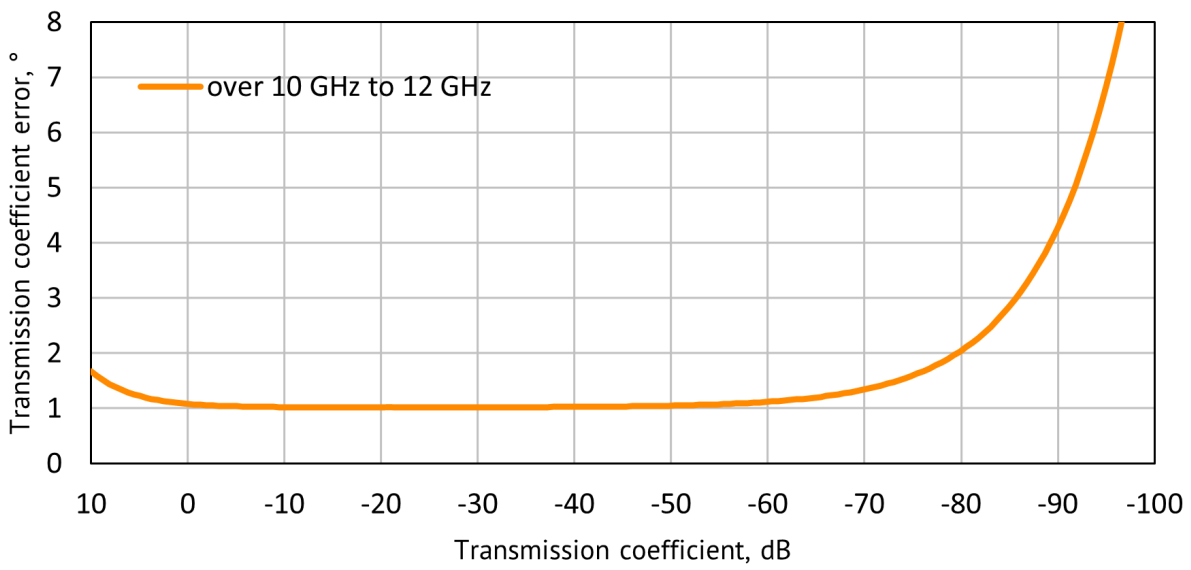
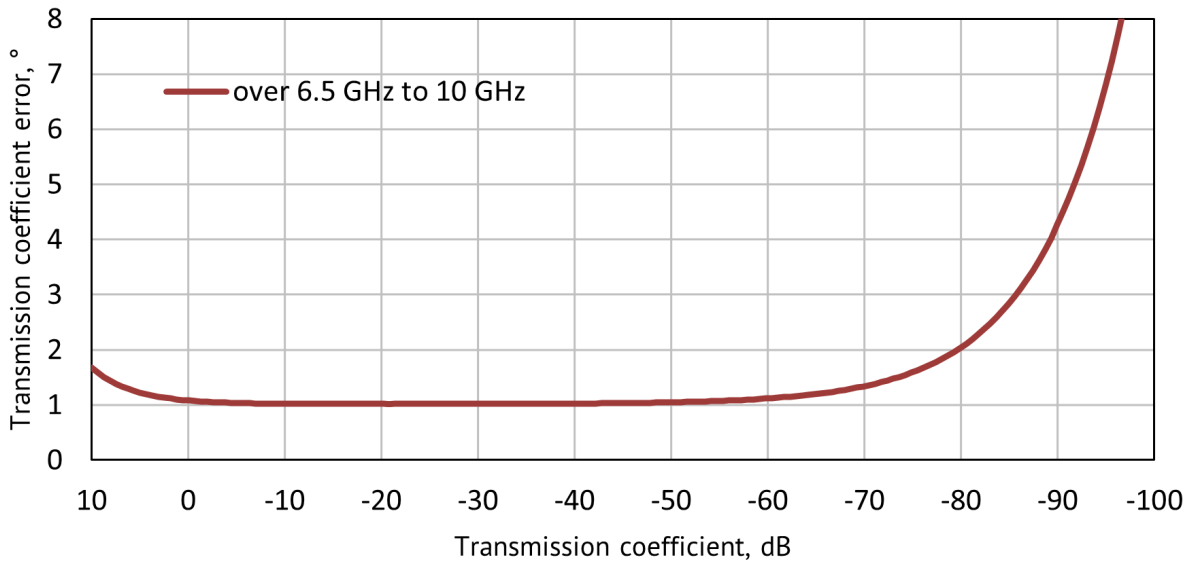

M5180 Value Series Vector Network Analyzer Specifications

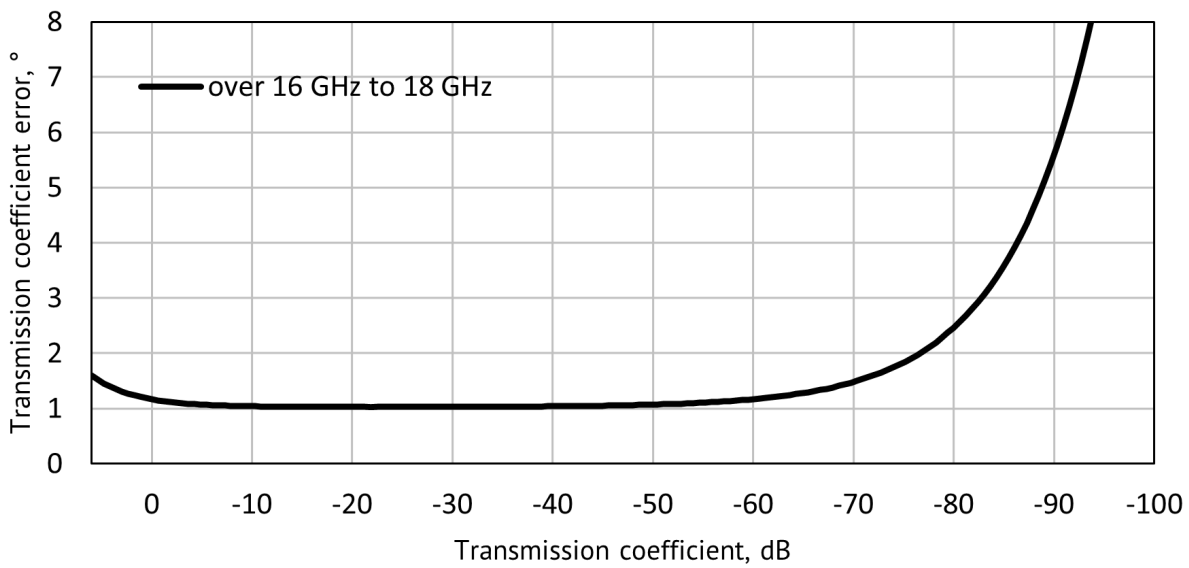
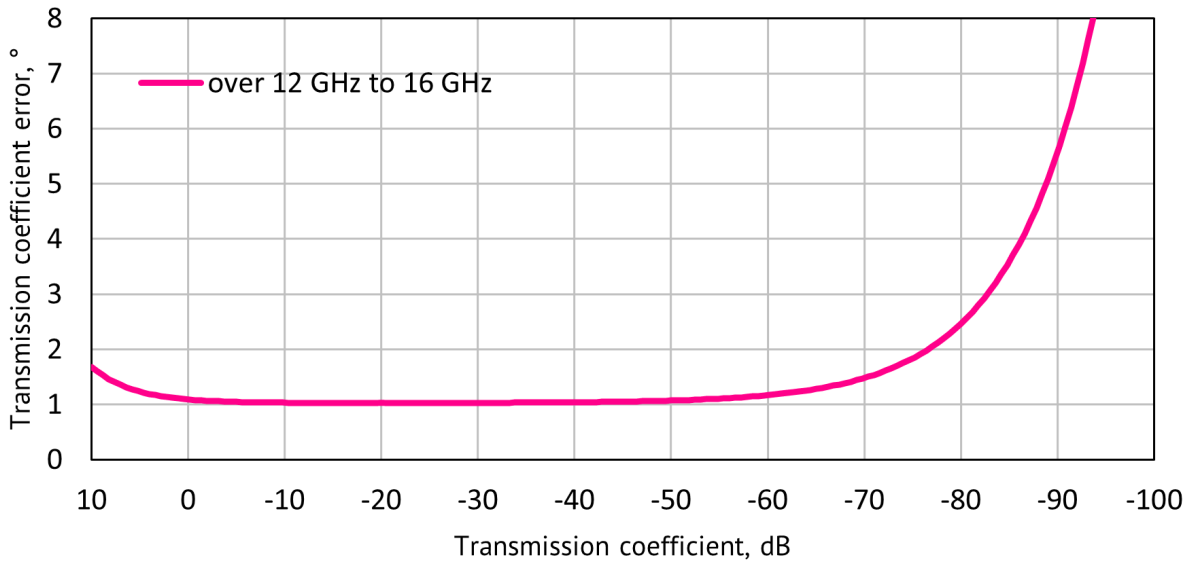

Specifications are based on a matched DUT, and IF bandwidth of 10 Hz

Transmission Magnitude Errors for Unmatched Devices

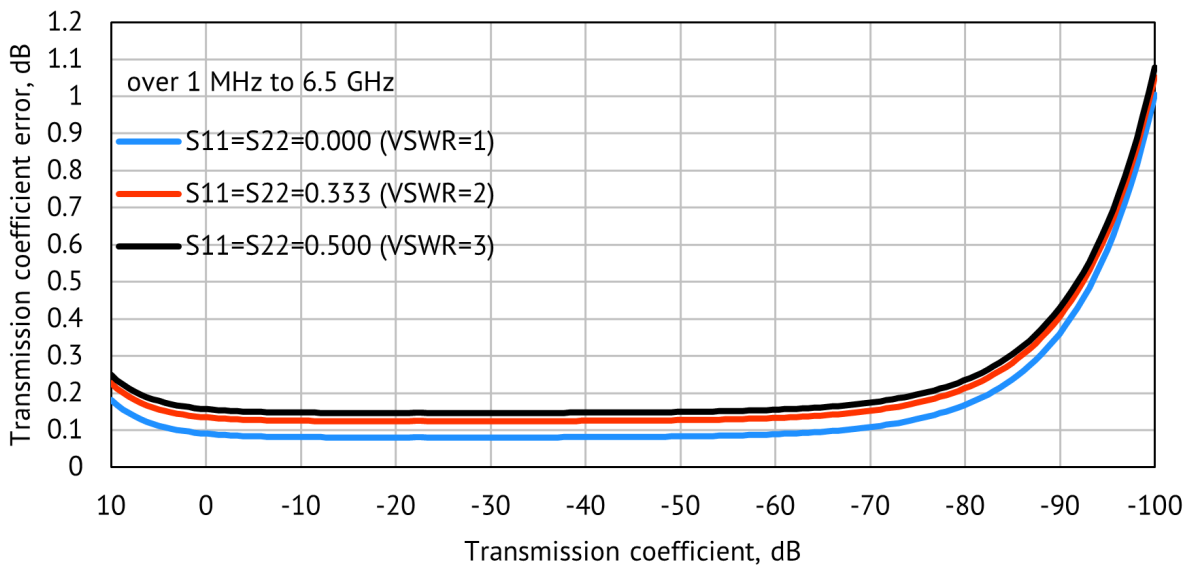
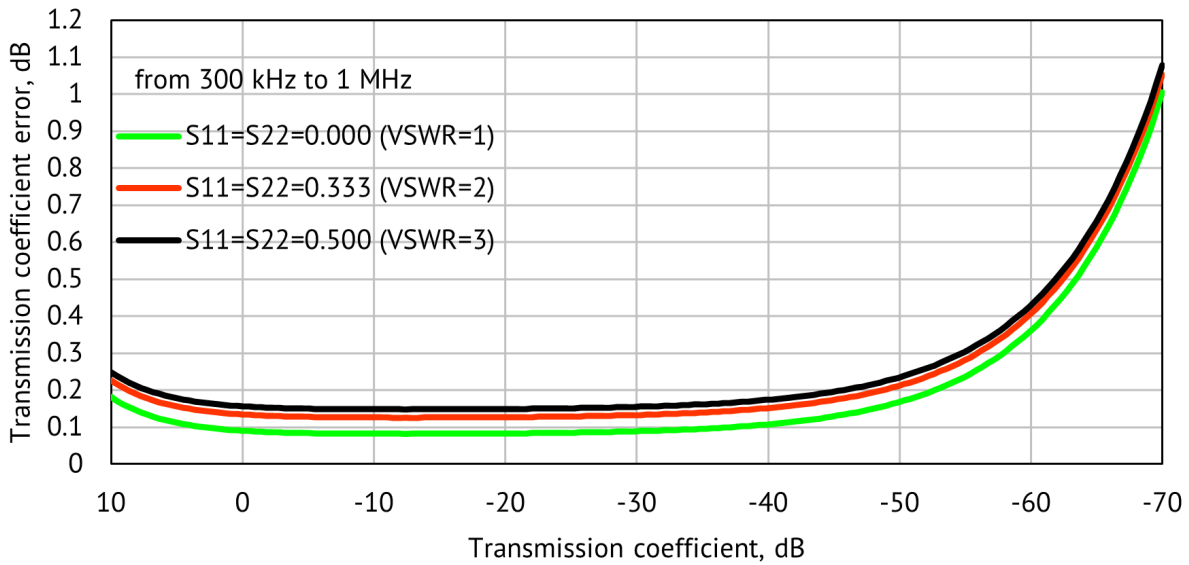

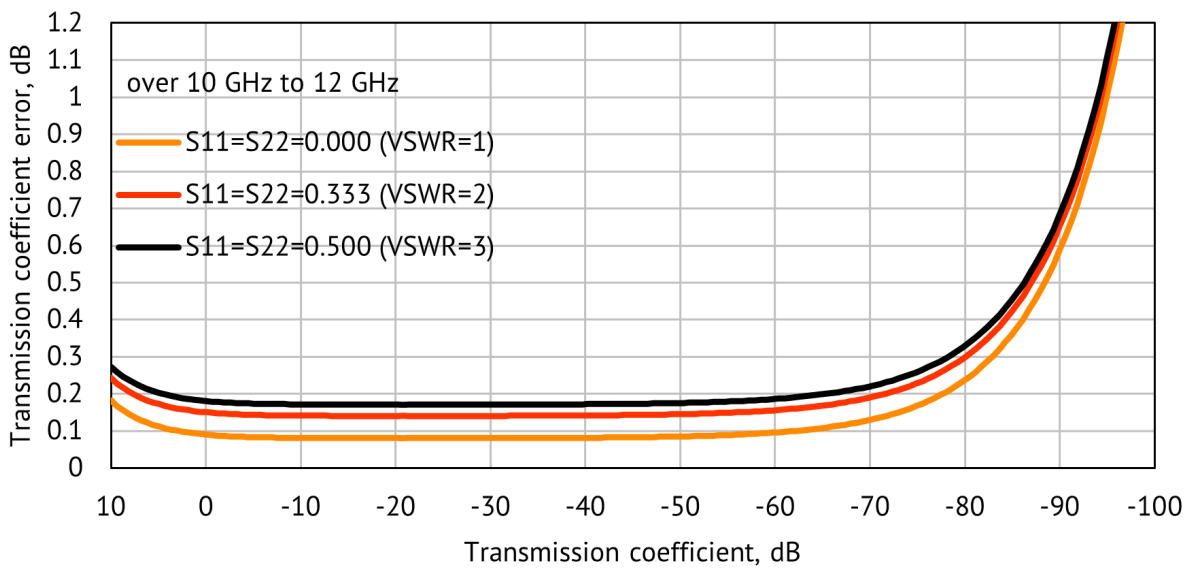
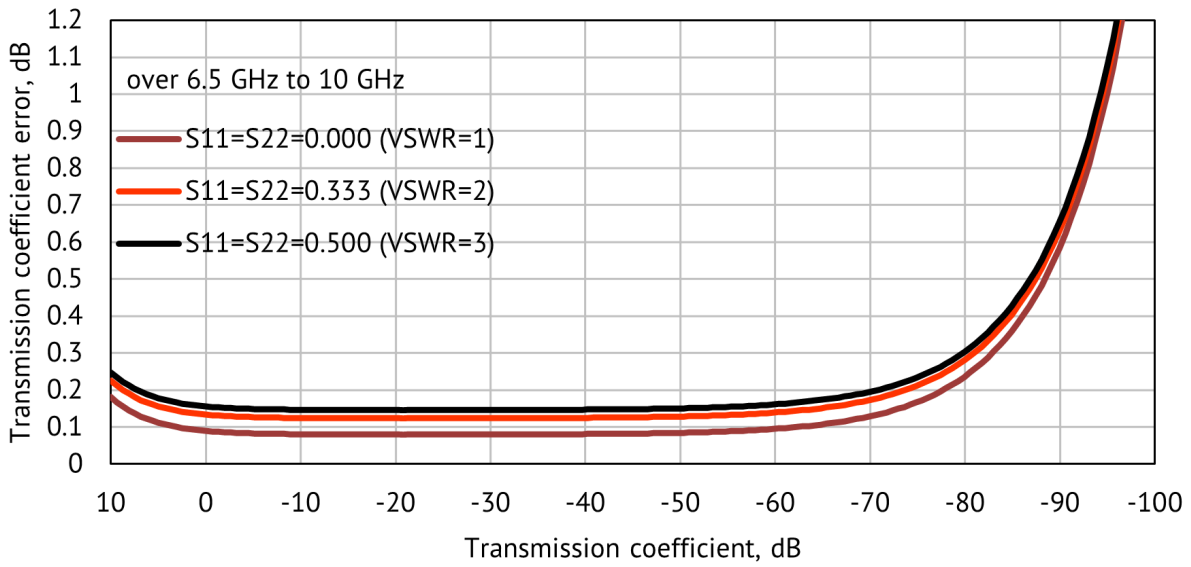

M5180 Value Series Vector Network Analyzer Specifications

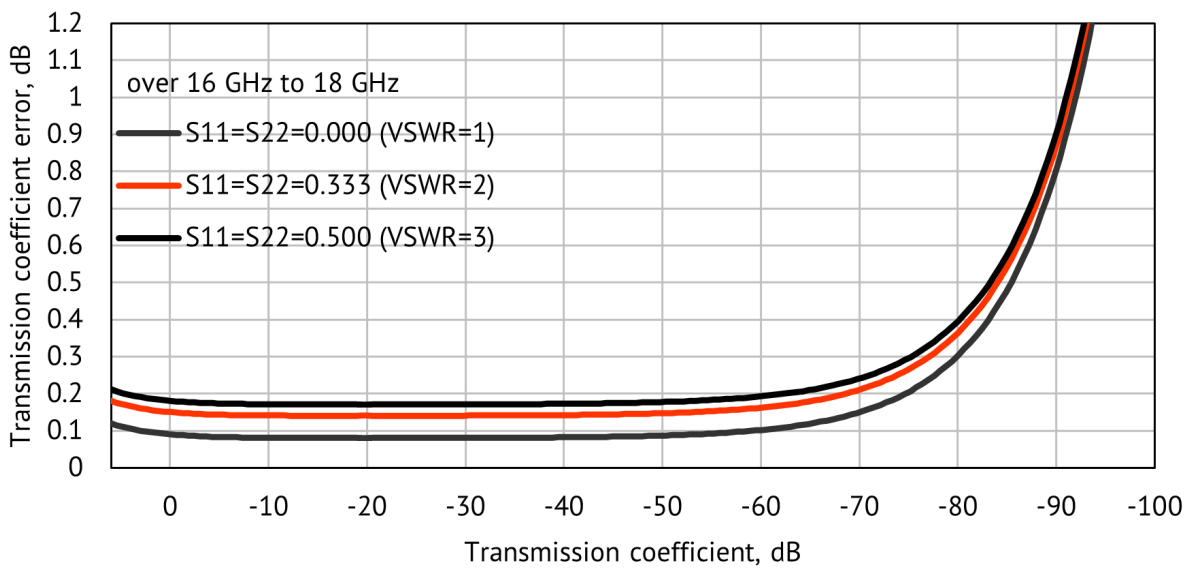
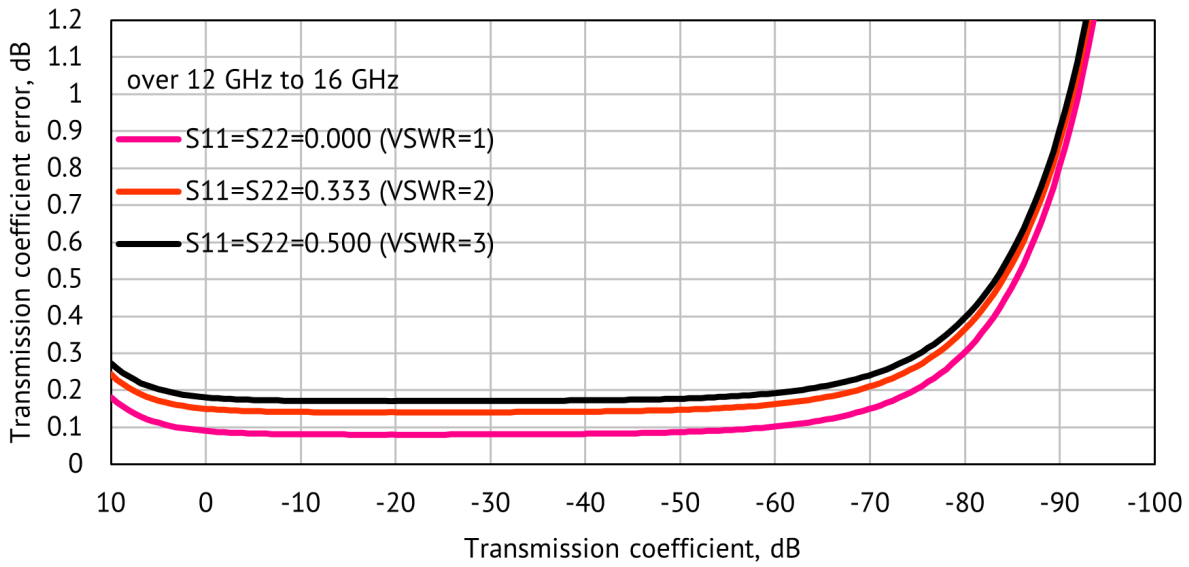

Transmission Phase Errors for Unmatched Devices

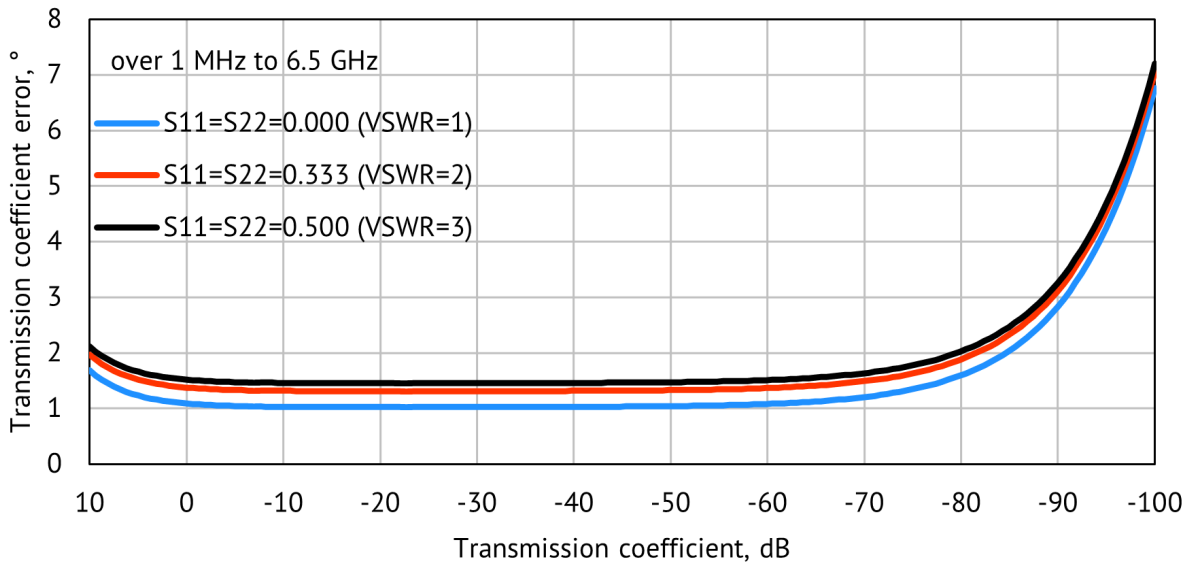
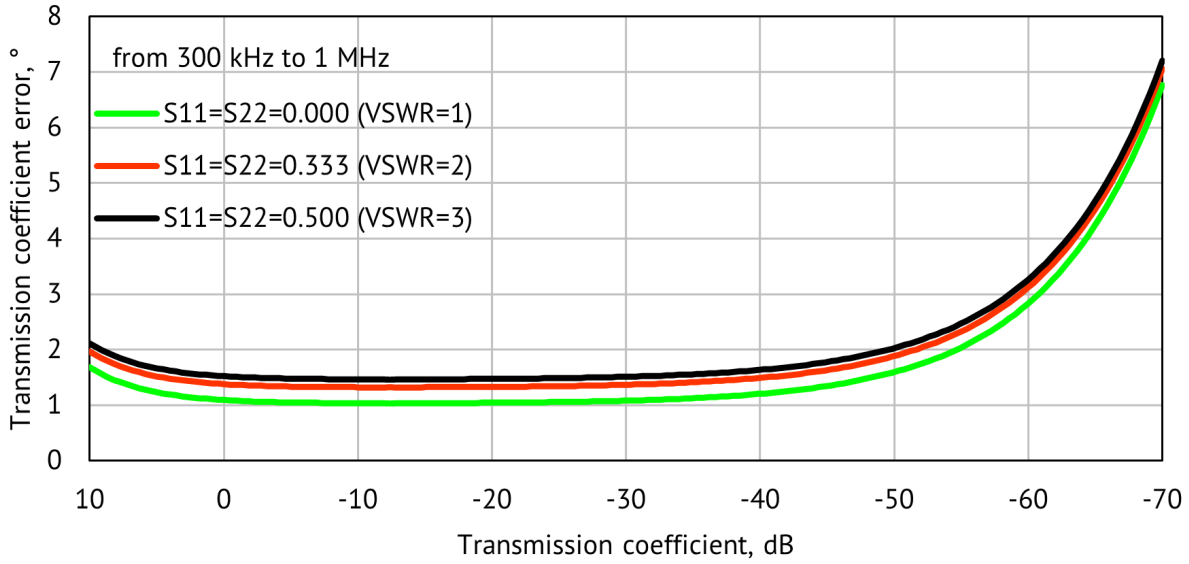

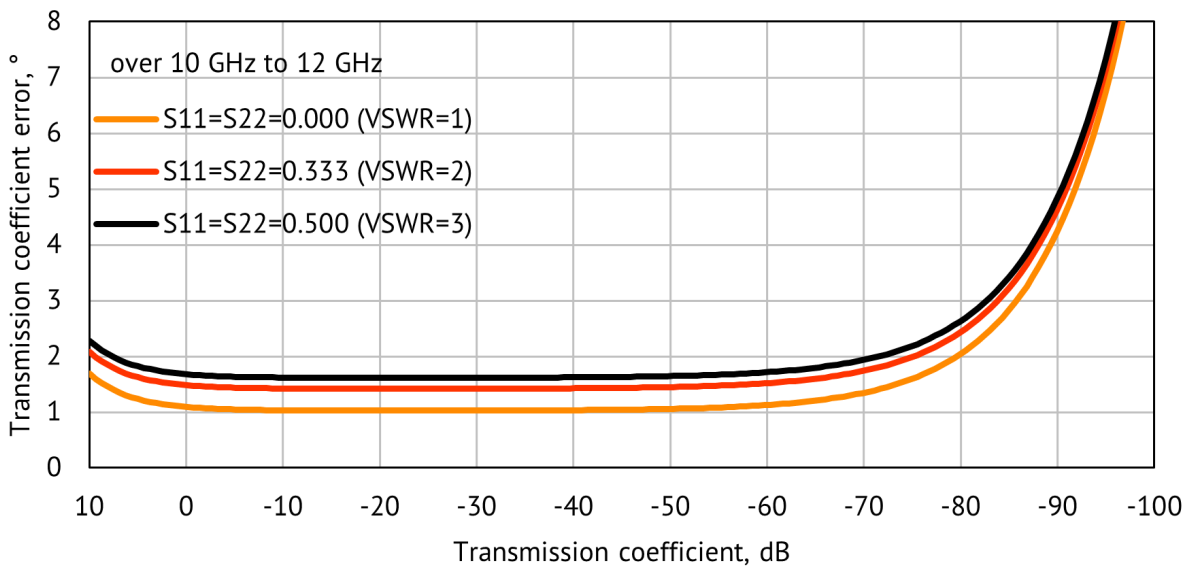
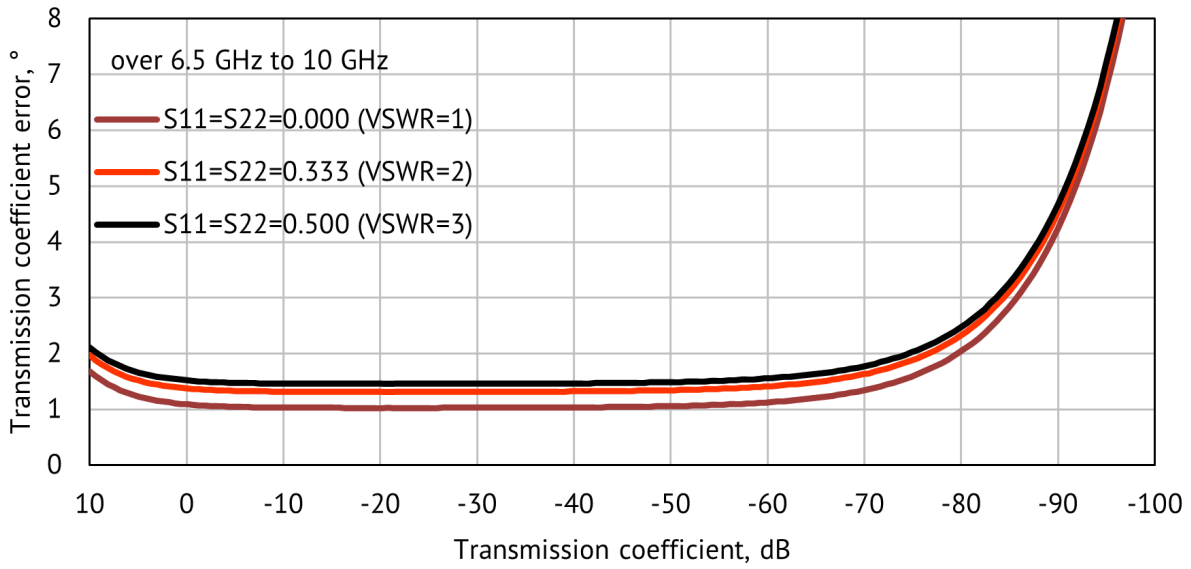

M5180 Value Series Vector Network Analyzer Specifications

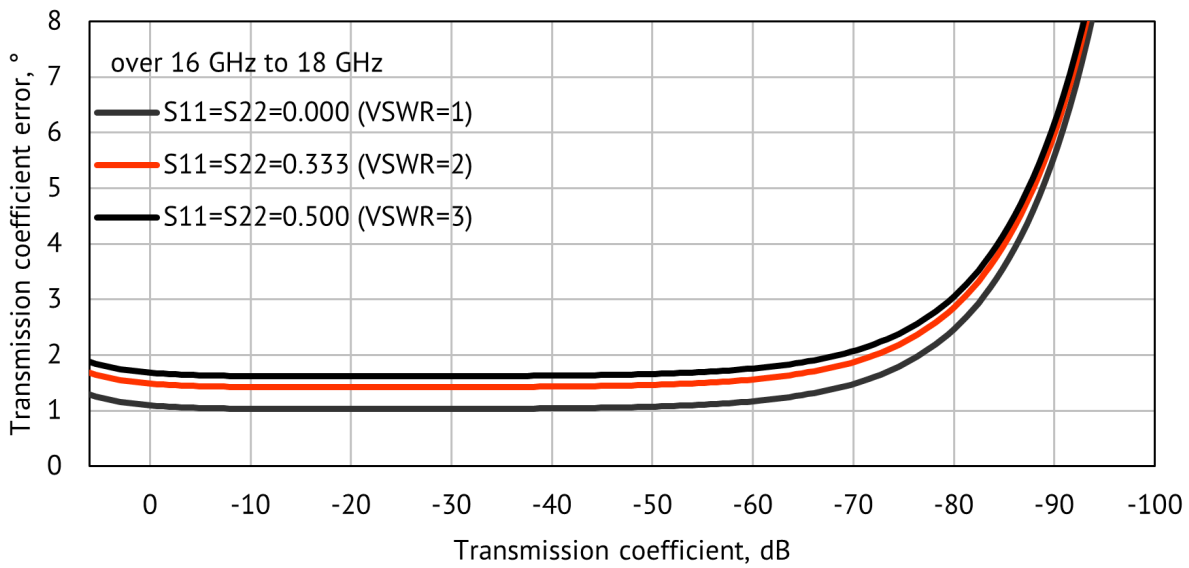
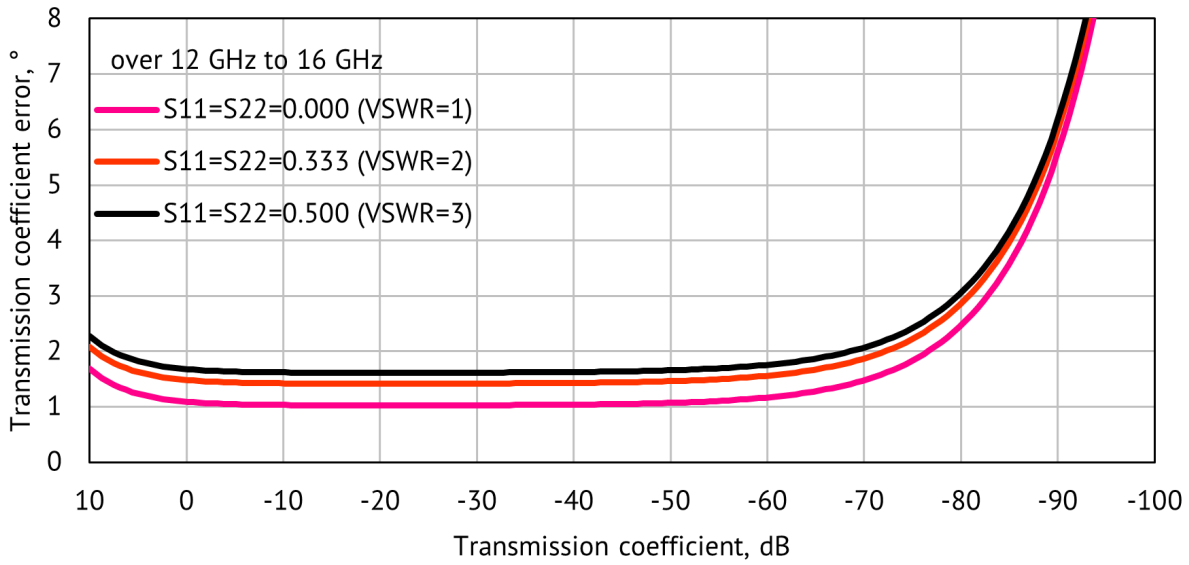

Transmission Errors for Matched Devices vs Output Power and IF Bandwidth

