



BFx-02 Frequency Extender Base Specifications



Frequency range	4 GHz to 20 GHz
Software	S2VNA

General Overview

BFx-02

Frequency range	4 GHz to 20 GHz
Software	S2VNA
S-parameter setup configuration	2-port, 2-path
Output power range	-4 dBm to +16 dBm
Number of points	2 to 500,001
Measurement bandwidths with (1/1.5/2/3/5/7 steps)	1 Hz to 1 MHz
Receiver noise floor	-140 dBm/Hz
Connection	USB

Service

Accredited Calibration Labs



Periodic verification is used to check the instrument to ensure that it is operating within its specifications. Two years is recommended, but the interval should be determined by your organization's quality policy.

Our Indianapolis and Cyprus calibration laboratories are accredited in accordance with the recognized international standard ISO/IEC 17025 (2017) and meet the requirements of ANSI/NCSL Z540-1994-1.

Warranty, Service, & Repairs

All our products come with a standard three-year warranty from date of shipment. During that time we will repair or replace any product malfunctioning due to defective parts or labor.

While we pride ourselves on quality of our instruments, should your VNA malfunction for any reason, we will gladly offer a loaner unit while we service yours. With our USB VNAs where all data is stored on your PC, a simple swap of the measurement module assures uninterrupted workflow and little or no downtime.

The Crown Customer Service Package

The package includes support that goes beyond the analyzer. Our expert engineers give guidance to customers using CMT analyzers regarding their measurement setup, automation, and much more. This package provides an unparalleled level of service before, during, and after the purchase of the analyzer. And the best part? It's included with every purchase from every company. We are always here to provide reliable and timely customer support.

Automation Support

We understand that your time is valuable, which is why our team strives to provide rapid support for engineers using automation in their testing. Because we want to keep you working, our Crown Customer Service package includes help with setting up your testing automation for your analyzer. Our engineers have lots of experience with many coding languages, like C++, Python, MATLAB*, Visual Basic (Excel)*, and LabVIEW*.



Supporting Unique Applications

Technological advancements have engineers using analyzers for more things than ever before.

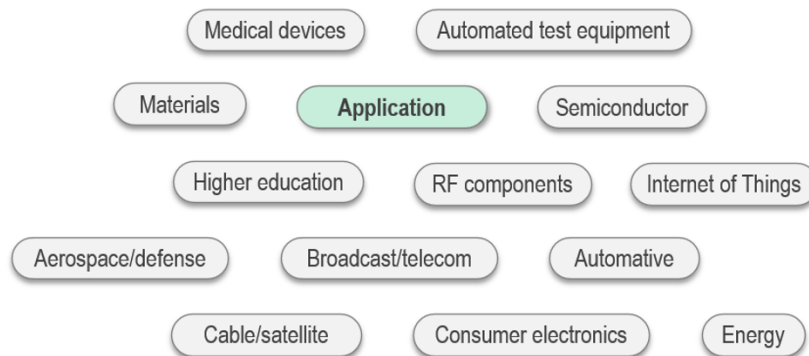

Customers are using CMT analyzers in industries such as agriculture, automotive R&D and manufacturing tests, medical applications, the expansive network of IoT and IIoT, energy, and more. Determining the ideal analyzer often requires extensive research, so the Crown Customer Support Package includes a consultation with our technical staff to discuss your specific application and recommend the best options. This support package comes at no charge with the purchase of a Copper Mountain Technologies VNA.

Having Issues with Your Analyzer?

We have built and supply high-quality test equipment we are proud of and stand behind. However, we know that issues happen, and when they do, we are here to help. Be it software support, repairs, or just a routine annual verification, the Crown Customer Service Package includes beyond-average rapid support for all of these occurrences. Our service and support teams do all they can to get the analyzer back to making accurate measurements as soon as possible.

For more detailed information, please visit our website:

<https://coppermountaintech.com/crown-customer-service-package/>

Software Capabilities

Software Capabilities Overview

Included Software Capabilities

Capability	Overview
Port extension	This function is useful when a fixture is used to connect to the DUT but calibration cannot be performed at the DUT terminals.
Mixer/converter measurements	Our analyzers allow users to perform measurements on mixers and other frequency converting devices using both scalar and vector methods.
Time domain measurements	Time-domain transformation enables the user to apply an inverse Fourier transform to frequency-domain data, producing the corresponding time-domain response.
Time domain gating	This function performs a time-domain transformation, selects a region of interest in the time domain, removes the response either inside or outside the selected region, and then transforms the modified data back to the frequency domain.
Limit testing	A function for automatic pass/fail based on measurement results.
Embedding	This function allows the user to mathematically simulate the DUT parameters after adding fixture circuits.
De-embedding	This function allows the user to mathematically exclude the effect of the fixture circuit existing between the calibration plane and the DUT from the measurement results.

Software Capabilities Extended

The S2VNA software includes many features that other vendors offer as paid options, including Time Domain capability, S-parameter Embedding and De-Embedding, Frequency Offset, and Vector Mixer Calibration functionality. No integrated PC means faster data processing turnaround and regular updates that are easy to install. Less complexity in the VNA leads to fewer points of failure that impact your design or production time.

All of the features listed below are included in the S2VNA software.

Sweep Features

Sweep type	Linear frequency sweep and logarithmic frequency sweep at fixed output power.
Measured points per sweep	Set by the user up to 500,001
Segment sweep features	<p>In applications where a contiguous sweep may be undesirable, this function allows the user to sweep frequency segments rather than the entire frequency span. This can lead to faster measurement results.</p> <p>A frequency sweep can be made within several independent user-defined segments. Frequency range, number of sweep points, source power, and IF bandwidth can be set for each segment.</p>
Sweep trigger	Trigger modes: continuous, single, or hold. Trigger sources: internal, manual, external, bus (programmatically controlled).

Trace Functions

The S2VNA software incorporates many trace functions, such as:

Trace display	Data trace, memory trace, or simultaneous indication of data and memory traces.
Trace math	Data trace modification by math operations: addition, subtraction, multiplication or division of measured complex values and memory data. S-parameters and raw receiver values may be manipulated. Amplifier stability factors can be displayed. Unbalanced to differential measurements may be calculated.
Autoscaling	Automatic selection of scale division and reference level value to have the trace most effectively displayed.
Electrical delay	Calibration plane movement to compensate for a delay between the calibrated reference plane and the Device Under Test (DUT) input.
Phase offset	Defined in degrees. Applies a chosen constant phase offset to S-parameter measurements at all frequencies.
Sweep trigger	Trigger modes: continuous, single, or hold. Trigger sources: internal, manual, external, bus (program controlled).

Mixer/Converter Measurements

<p>Scalar mixer/converter measurements</p>	<p>The scalar method allows the user to measure the magnitude of the conversion loss of a mixer or other frequency-translating device. No additional mixers or other devices are required. The scalar method employs port frequency offset when there is a difference between the source port frequency and the receiver port frequency.</p>
<p>Scalar mixer/converter calibration</p>	<p>This is the most accurate method of calibration applied for measurements of mixers in frequency offset mode. Open, Short, and Load calibration standards are used for 1-port calibration on each port. An external USB power meter is then used to accurately measure stimulus source power such that a calculated cross-band Thru is achieved for correction of the transmission tracking error.</p>
<p>Vector mixer/converter measurements</p>	<p>The vector method allows measurement of both the magnitude and phase of the mixer conversion loss. This method requires a reference mixer and an LO common to both the reference mixer and the mixer under test. The reference mixer is required to put Ports 1 and 2 at the same frequency such that phase measurements are possible. The reference mixer is de-embedded during vector mixer calibration.</p>
<p>Vector mixer/converter calibration</p>	<p>This method of calibration is applied for vector mixer measurements. Open, Short, and Load calibration standards are used. The reference mixer is de-embedded by this calibration.</p>
<p>Automatic frequency offset adjustment</p>	<p>This function performs automatic frequency offset adjustment when the scalar mixer/converter measurements are performed to compensate for LO frequency inaccuracy.</p>
<p>Sweep trigger</p>	<p>Trigger modes: continuous, single, or hold. Trigger sources: internal, manual, external, bus (program controlled).</p>

Time Domain Measurements

This function performs conversion of the response of the DUT from frequency domain to time domain. Modeled time domain stimulus types are bandpass, lowpass impulse, and lowpass step. The time domain span is determined by the frequency span and the number of measurement points. Windowing functions of various shapes are used for tradeoff between resolution and levels of spurious sidelobes.

Time Domain Gating

This function mathematically removes unwanted responses in the time domain, allowing the user to obtain a frequency response without the effects of fixture elements. Reflections occurring within a chosen time span may be bandpass gated such that all other reflections are suppressed or notch gated such that reflections in the chosen time span are suppressed.

After time domain gating, the result with chosen reflections removed may be viewed in the frequency domain. Gating filter types are bandpass or notch. For a better tradeoff between gate resolution and level of spurious sidelobes the following filter shapes are available: maximum, wide, normal and minimum.

Embedding

This feature allows the user to mathematically add a virtual circuit defined by a Touchstone file to any VNA port. This function might be used to test impedance matching on a DUT.

De-embedding

This feature allows the user to mathematically remove a circuit defined by a Touchstone file from the measurements on any VNA port. This might be used to remove the effects of fixture connections or pigtail cable connections to a DUT.

Limit Testing

Limit testing is a function for automatic pass/fail based on measurement results. Pass/fail is based on a comparison of the trace to the limit line set by the user and can consist of one or several segments.

Each segment checks the measurement value for failing either the upper or lower limit, or both. The limit line segment is defined by specifying the coordinates of the beginning (X0, Y0) and the end (X1, Y1) of the segment, and the type of limit. The MAX or MIN limit types check if the trace falls below or above the limit line, respectively.

Port Impedance Conversion

This function converts the S-parameters measured at a 50 Ω port into values which would be seen if measured at a test port with an arbitrary impedance.

S-Parameter Conversion

This function allows for conversion of measured S-parameters to the following parameters: reflection impedance and admittance looking at a grounded DUT, transmission impedance and admittance looking through a DUT, transmission impedance and admittance looking across the top of a grounded DUT using a 2-Port measurement, and inverse S-parameters.

State saving	<p>Analyzer State</p> <p>All state, calibration and measurement data can be saved to an Analyzer state file on the hard disk and later recalled into the software program. The following four types of states are available: State, State & Cal, State & Trace, or All.</p> <p>Channel State</p> <p>A channel state can be saved into the Analyzer state. The procedure is similar to saving of the Analyzer state, and the same types are applied to channel saving. Unlike Analyzer state, channel state is saved into the Analyzer volatile memory (not to the hard disk) and is cleared when power to the Analyzer is switched off. For channel state, there are four memory registers A, B, C, D. Channel state saving allows the user to easily copy the settings of one channel to another one.</p>
---------------------	--

Data Output

<p>Trace data CSV file</p>	<p>The Analyzer allows the user to save an individual trace's data as a CSV file (comma separated values). The active trace stimulus and response values in its current format are saved to a *.CSV file.</p>
<p>Trace data Touchstone file</p>	<p>Allows the user to save S-parameters to a Touchstone file. The Touchstone file contains frequency values and S-parameters. Files of this format are industry-standard for most circuit simulator programs. The .s2p files are used for saving all S-parameters of a 2-port device. The .s1p files are used for saving S11 or S22 parameters of a 1-port device. The Touchstone file saving function is applied to individual channels. In addition, the software can be used as a Touchstone file viewer, which allows the user to graphically display and work with previously saved Touchstone files. Normally, trace transforms such as time-domain gating are not saved to a Touchstone file, but enabling "Including Trace Transform" will allow this.</p>
<p>Screenshot capture</p>	<p>A print function is provided with a preview feature, which allows for viewing an image of the screen, and/or save it to a file. Screenshots can be printed using three different applications: MS Word, Image Viewer for Windows, or the Print Wizard of the Analyzer. Each screenshot can be printed in color, grayscale, black and white, or inverted for visibility or to save ink. The current date and time can be added to each capture before it is transferred to the printing application, resulting in quick and easy test reporting. A Word template file in the C drive VNA folder image directory may be customized to change the appearance of the MS Word file output.</p>

User Calibration

<p>Calibration</p>	<p>Calibration of a test setup (which includes the VNA, cables, and adapters) significantly increases the accuracy of measurements. Calibration allows for correction of errors caused by imperfections in the measurement system: system directivity, source and load match, tracking, and isolation.</p>
<p>Calibration methods</p>	<p>The following calibration methods of various sophistication and accuracy are available:</p> <ul style="list-style-type: none"> • Reflection and transmission normalization • Full one-port calibration • One-path two-port calibration • Full two-port calibration
<p>Reflection and transmission normalization</p>	<p>This is the simplest calibration method; however, it provides reduced accuracy compared to other methods.</p>
<p>Full 1-port calibration</p>	<p>Method of calibration performed for 1-port reflection measurements. It ensures high accuracy.</p>
<p>1-path 2-port calibration</p>	<p>Method of calibration performed for reflection and one-way transmission measurements; for example, for measuring s_{11} and s_{21} only. It ensures high accuracy for reflection measurements, and moderate accuracy for transmission measurements. Commonly used when an attenuator must be attached to the receiving port as in the measurement of a high-power amplifier.</p>
<p>Full two-port calibration</p>	<p>This method of calibration is performed for full S-parameter matrix measurement of a two-port DUT, ensuring high accuracy.</p>
<p>Mechanical calibration kits</p>	<p>The user can select one of the predefined calibration kits of various manufacturers or define a new calibration kit.</p>

<p>Sliding load calibration standard</p>	<p>The use of a sliding load calibration standard allows for a significant increase in calibration accuracy at high frequencies compared to the fixed load calibration standard.</p>
<p>Unknown thru calibration standard</p>	<p>The use of a generic 2-port reciprocal circuit instead of a characterized Thru in full 2-port calibration allows the user to calibrate the VNA for measurement of “non-insertable” devices. Unknown thru should be used by default for SOLT (SOLR) calibrations.</p>
<p>Defining of calibration standards</p>	<p>Different methods of calibration standard definition are available: standard definition by polynomial model and standard definition by Touchstone data file (S-parameters).</p>
<p>Error correction interpolation</p>	<p>When the user changes any settings such as the start/stop frequencies or the number of sweep points, compared to the settings at the moment of calibration, interpolation or extrapolation of the calibration coefficients will be applied. Extrapolation is not recommended for accurate measurements.</p>
<p>Receiver calibration</p>	<p>This method calibrates the receiver gain at the absolute signal power measurement.</p>

Automation Languages

We maintain code examples and guides in the following languages:

- Python*
- C++*
- LabVIEW
- VBA
- MATLAB

*Available for use with Linux operating system

Measurement Automation

SCPI via TCP Socket	A TCP socket is provided for automation from either localhost--the same machine running the VNA software application--or from a second PC connected by an IP network. SCPI commands are largely compatible with legacy instruments, maximizing code reuse for existing test automation platforms. SCPI via TCP Socket is compatible with either Windows or Linux operating systems.
SCPI via HiSlip	Based on VXI-11, the HiSlip interface uses the same SCPI command set but further allows for instrument discovery and provides ease of automation through Visa library of your choice. SCPI via HiSlip are compatible with either Windows or Linux operating systems.
LabVIEW compatible	The device and its software are fully compatible with LabVIEW applications for ultimate flexibility in user-generated programming and automation. LabVIEW are only compatible with Windows operating systems.

Our command set is modeled after industry-standard legacy equipment; porting code is straightforward, and we can help. Complete installation of CMT software comes with multiple programming examples and guides installed in the C drive VNA folder under Programming Examples and Guides directory on Windows or ~/Documents/VNA directory on Linux.

Standard Software Features

- Segmented frequency sweeps
- Linear/logarithmic sweeps
- Multiple trace formats
- 16 channels max with up to 16 traces each
- Marker math
- Trace math
- Limit tests

Hardware Specifications

Block Diagram

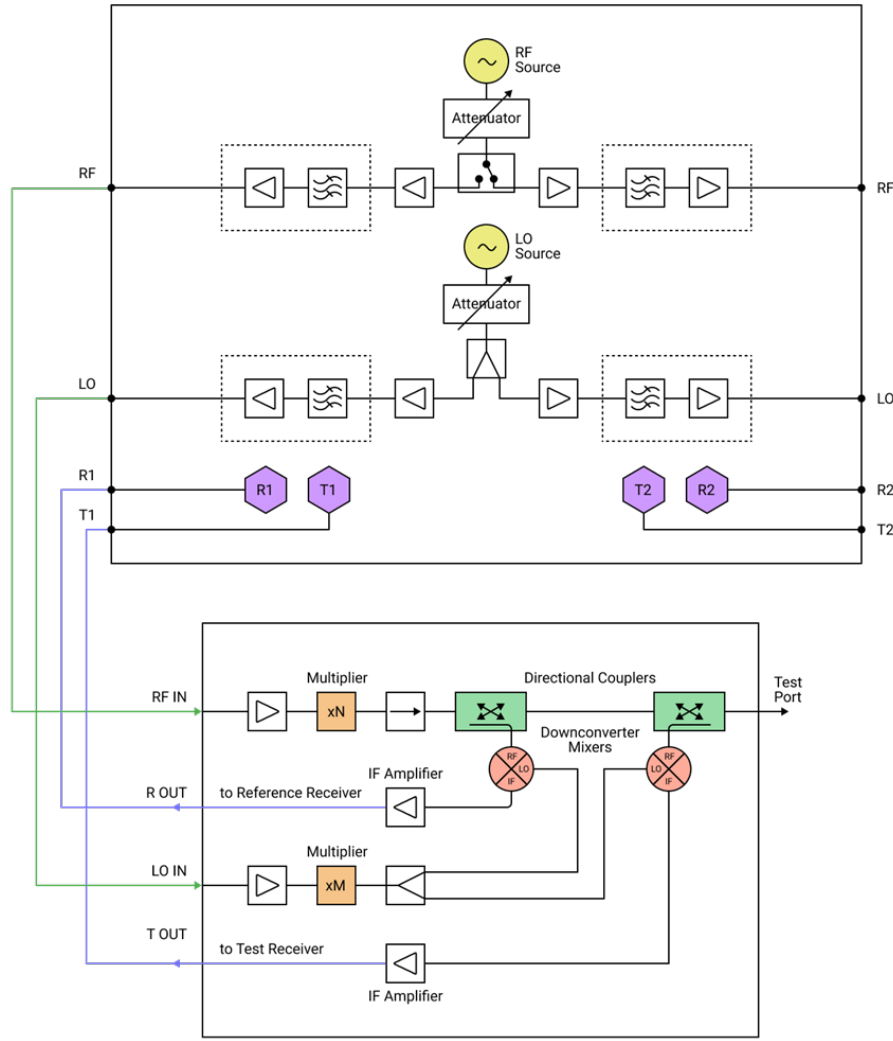

BFx-02

Standard
Frequency
Extender

BFx-02 Connection Diagram

BFx-02

Measurement Range¹

Operating mode	Frequency extension
S-parameter setup configuration	2-port, 2-path
Signal sources	
Operating mode	PLL-based frequency synthesis
Frequency range	4 GHz to 20 GHz
Output power range	-4 dBm to +16 dBm
Number of points	2 to 500,001
RF signal path	2 ports: switchable
LO signal path	2 ports: power splitting
Receiver	
Operating mode	Fixed frequency
Nominal frequency	109.75 MHz
Dynamic range ²	130 dB
Measurement bandwidths (with 1/1.5/2/3/5/7 steps)	1 Hz to 1 MHz
Receiver path	4 ports
High sensitivity mode	Supported
Connection	USB
Software	S2VNA

[1] All specifications subject to change without notice.

[2] The dynamic range is defined as the difference between the specified 0.1 dB compression level and the specified noise floor. The specification applies at 10 Hz IF bandwidth.

Signal Sources: RF and LO ports

Frequency	
Range	4 GHz to 20 GHz
Accuracy	$\pm 5 \cdot 10^{-6}$
Resolution	1 Hz
Output power	
Range	-4 dBm to +16 dBm
Accuracy	± 2 dB
Resolution	0.05 dB
Impedance	50 Ohm
Connector type	SMA female

Receivers³

Nominal frequency	109.75 MHz
0.1 dB compression	
High sensitivity OFF	0 dBm
High sensitivity ON	-20 dBm typ.
Low noise amplifier gain	22 dB typ.
Receiver noise floor	-140 dBm/Hz
Linearity within -10 to -70 dBm input range	0.1 dB typ.
Measurement bandwidths (with 1/1.5/2/3/5/7 steps)	1 Hz to 1 MHz
Trace noise magnitude	0.002 dB rms
Temperature dependence	0.02 dB/°C
Test receiver port designation	T1, T2
Reference receiver port designation	R1, R2
Impedance	50 Ohm
Connector type	SMA, female

[3] Unless otherwise specified, the parameters are given for the high sensitivity OFF mode.

Frequency Reference Input

Port designation	REF 10 MHz IN
External reference frequency	10 MHz
Input level	-2 dBm to 4 dBm
Input impedance	50 Ohm
Connector type	BNC, female

Frequency Reference Output

Port designation	REF 10 MHz OUT
Internal reference frequency	10 MHz
Output reference signal level at 50 Ohm impedance	0 dBm to 2 dBm
Connector type	BNC, female

Trigger Input

Number of ports	1
Port designation	TRIGGER IN
Input level	
Low threshold voltage	0.8 V
High threshold voltage	2.7 V
Input level range	0 V to +5 V
Pulse width	$\geq 2 \mu\text{s}$
Polarity	positive or negative
Input impedance	$\geq 10 \text{ k}\Omega$
Connector type	BNC, female

Trigger Output

Number of ports	1
Port designation	TRIGGER OUT
Maximum output current	20 mA
Output level	
Low level voltage	0.4 V
High level voltage	3.0 V
Polarity	positive or negative
Connector type	BNC, female

Measurement Speed

Time per point	15 μ s typ.
Port switchover time	7 ms

Power and Control Connector

DC voltage	+6.5 V, 2 A max
Control voltage ⁴	TTL-compatible
Connector type	LEMO EGG.0B.304.CLL

[4] Logic high indicates the mode where RF PORT 1 is the signal source.

System and Power

Operating system (min requirements)	Windows 10 and above
CPU	4 core 2.0 GHz (x64)
RAM	4 GB
Interface	USB 2.0
Connector type	Type C
Power supply (main outlet)	110-240 V, 50/60 Hz
Power consumption (main outlet)	75 W

Dimensions

Length	326 mm
Width	231 mm
Height	107 mm
Weight	4.4 kg

Environmental Specifications

Operating condition	
Temperature	+5 °C to +40 °C (41 °F to 104 °F)
Humidity	90 % at 25 °C (77 °F)
Storage	
Temperature	+0 °C to +40 °C (32 °F to 104 °F)
Humidity	80 % at 35 °C (95 °F)
Non-operating temperature	-50 °C to +70 °C (-58 °F to 158 °F)
Atmospheric pressure	70.0 kPa to 106.7 kPa