

9 GHz VNA-Compatible Frequency Extenders

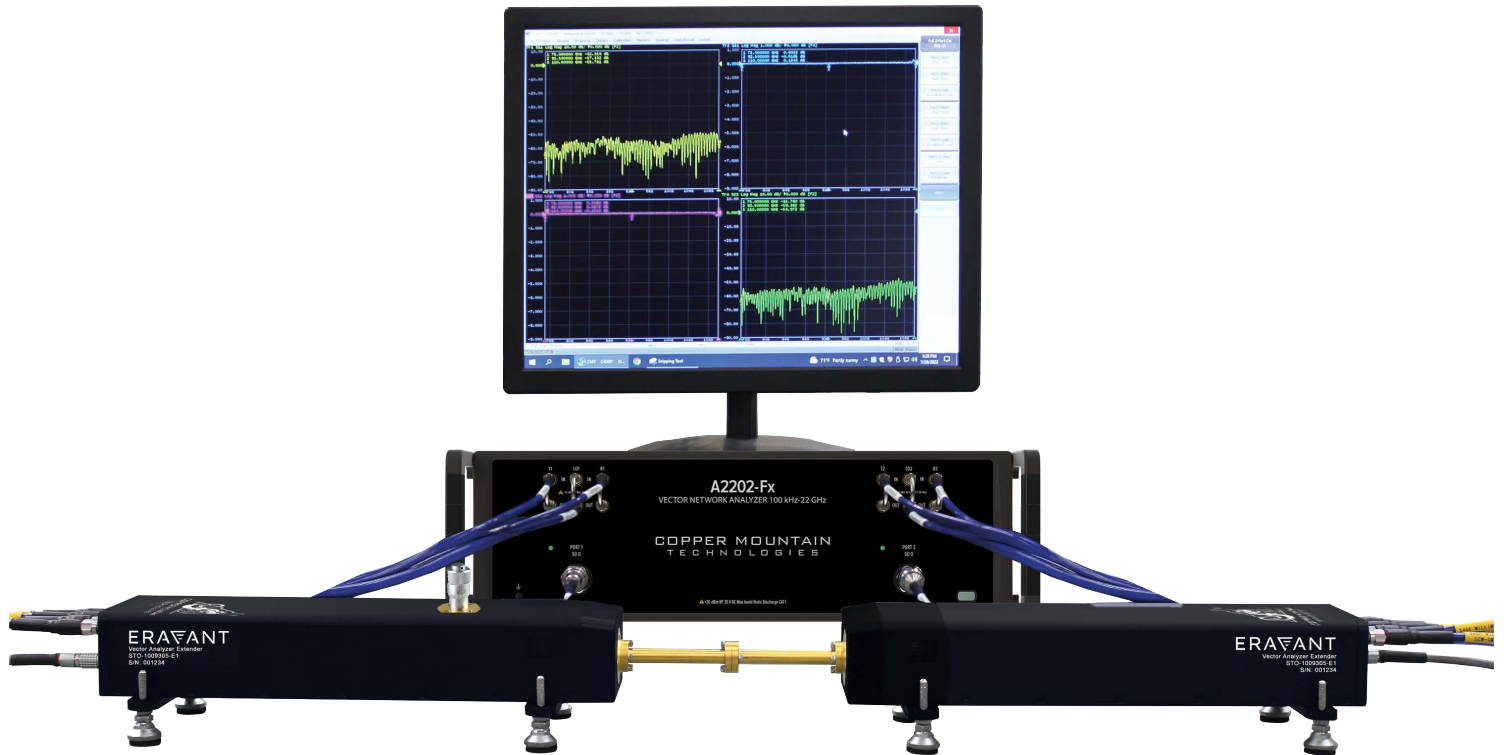

- **Frequency extension system**

- Waveguides bands of

- WR-15 (50-75 GHz)
- WR-12 (60-90 GHz)
- WR-10 (75-110 GHz)
- WR-8 (90-140 GHz)

- Optional adjustable power output (attenuator) available

- Models with high or low output power*
- Anchored with any 9 GHz or 20 GHz frequency extension-compatible VNAs
- Waveguide modules built in collaboration with Eravant (formerly Sage Millimeter)

Cost-effective mmWave Measurements

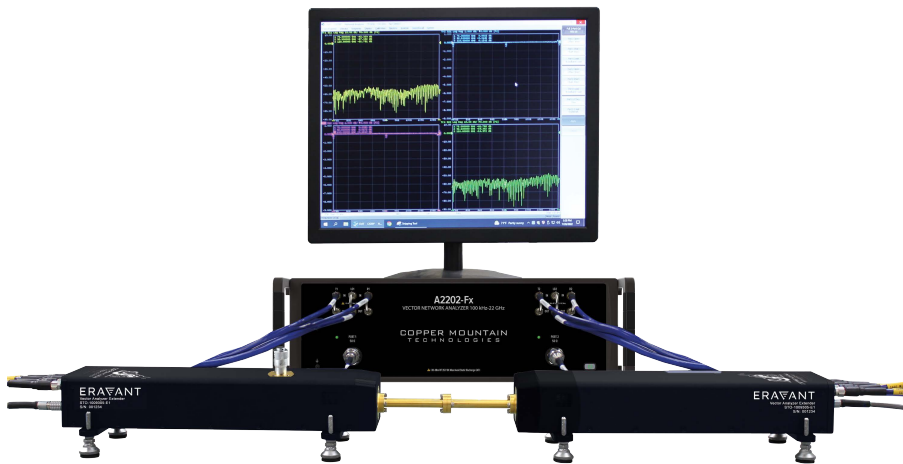

CobaltFx is a millimeter-wave frequency extension solution, the first that can be anchored by a 9 GHz or a 20 GHz VNA. CobaltFx series allows engineers to build a scalable and affordable 5G testing solution. Each frequency band can be incorporated into the CobaltFx solution as needed, allowing for easy expansion of the range of 5G components and products tested in development and production and smaller upfront investment. This cost-effective millimeter wave frequency extension system offers industry leading dynamic range and sweep speeds.

CobaltFx's high dynamic range and directivity allow for highly accurate and stable millimeter-wave S-parameter measurements in many dedicated frequency bands:

- WR-15 (50-75 GHz)
- WR-12 (60-90 GHz)
- WR-10 (75-110 GHz)
- WR-8 (90-140 GHz)

CobaltFx offers an unparalleled combination of price, performance, flexibility and size. The VNAs used in this system are from Copper Mountain Technologies' industry leading Cobalt Series. They feature fast sweep speeds down to 0.2 microseconds per point and a dynamic range of up to 152 dB, all comprised in a compact, USB form factor. Frequency extension modules are developed with Eravant, formerly Sage Millimeter, a globally recognized brand in millimeter-wave development.

Copper Mountain Technologies offers a Booster Set in cases when frequency extenders are located at a distance from the VNA or require amplification of the RF, LO and IF signals, for example with third party frequency extenders. Booster Set can be used with 9 GHz and 20 GHz instruments. It increases the upper limit of RF and LO signals' output power to 13 dBm. Booster Set includes module, external amplifiers, and adapters. Connecting cables depend on required length and are not a part of the set.

Copper Mountain Technologies' USB VNAs are next generation analyzers designed to meet the needs of 21st Century engineers. Our VNAs include an RF measurement module and a processing module, a software application which runs on a Windows or Linux PC, laptop, or tablet, connecting to the measurement hardware via USB interface.

This innovative approach delivers high measurement accuracy and enables users to take advantage of faster processors, newer computers and larger displays. USB VNAs have lower Total Cost of Ownership and fewer potential failure points. These instruments are smaller and lighter, can go almost anywhere, are very easy to share and eliminate the need for data purging or hard drive removal in secure environments.

“Frost & Sullivan analysis confirms that CMT distinguishes itself from competition by offering quality measurement VNAs that provide reliable results, yet are small, can be simply integrated into systems, and are more affordable than traditional analyzers.”

– Jessy Cavazos | Industry Director, Frost & Sullivan



Applications and Examples

Antenna Range Measurements

Due to high free space loss between the transmitting and receiving antennas, near and far field antenna measurements as well as radar cross section measurements require high dynamic range and a fast-sweeping test system. During the measurement, antenna gain, pattern, efficiency and directivity can be verified, as well as parameters of a radome. Directivity and reflectivity measurements are fundamental for evaluating the backscatter parameters of the target. All these measurements can be performed by a millimeter wave S-parameter measurement system. CobaltFx offers industry-leading dynamic range and sweep time, as well as stability and ease of use.

Material Characterization

Increase in usage of millimeter waves for high speed digital radio communications and radar sensors is driving the need for high frequency characterization of various materials: PCB laminates, antenna radomes and lenses, vehicle windscreens and various other dielectric composites. Accurate characterization is fundamental to understanding frequency-dependent dielectric constant and loss tangents that allow for better modeling of structures, shorter development times and ultimately lower cost of products. The CobaltFx system is designed to be used for various methods of material characterization – free space, transmission line and resonance

type. It offers an accurate, compact and cost-effective way of understanding the impact of various materials on high frequency performance in millimeter wave components and systems.

Wafer S-Parameter Measurements

On wafer S-parameters measurements provide for model generation of discrete semiconductor devices (diodes, transistors, mmics etc.). For accurate models, the data obtained during measurements must be accurate and the system must allow for long time intervals between calibrations. Such tasks require that millimeter-wave test equipment is stable and accurate while at the same time being compact and flexible. CobaltFx fits those two criteria perfectly.

5G Applications

5G technology is considered to be a fundamental medium for the Internet of Things (IoT). It is believed that 5G will enable very diverse bandwidth usage with challenging requirements (up to 1Tb/s/km² by 2030). With 3D/4K video streaming, vast millimeter wave and smart camera sensor networks, working in the cloud, autonomous driving and mission-critical broadcasting all planned to be part of IoT, the need for bandwidth and data transmission speed has never been greater. Unlocking the high mmWave part of the frequency spectrum (24-100 GHz) is fundamental to this concept. Such a system will be based on small antennas operating in standalone as well as multiple user arrangements with beamforming capabilities, where amplitude and phase shift need to be very well characterized. Base stations as well as handset devices will require comprehensive discrete components as well as system level characterization. The system to be deployed and consumer devices need to comply with very strict specifications and emission requirements, but also meet low cost requirements. CobaltFx is the most cost-effective solution to enable the integration of various devices, materials, antenna beamforming and channel propagation concepts for indoor and outdoor 5G communication.



Applications & Examples

Benchtop DUT Characterization

Benchtop S-parameter measurements allow for accurate and time-effective verification of packaged products. Every test laboratory in a commercial or industry orientated organization involved in production and testing of various components must have a means of evaluating their products. These normally involve DUT-type unilateral or bilateral S-parameter measurements of passive and active components, compression point measurements for amplifiers and mixers, and intermodulation distortion. The measurement domain is either frequency or time. CobaltFx allows for all these measurements and with its flexibility and compactness it easily fits on the bench. It also fits the financial constraints that every commercial organization must take into account. What all these applications have in common is that they require an accurate, compact and affordable millimeter wave test and measurement solution and CobaltFx meets all these criteria.

Measurement Capabilities

Multi Gigabit WiFi technology operating at 60 GHz will expand capacity for indoor WiFi data transmission. With 3D and 4K video streaming within the wireless network and devices, there is a need for chipset and antenna technology to offer bandwidth and range that will reliably replace cable connectivity. Such applications put big constraints on the cost of the router as well as wireless devices. High levels of integration of various technologies, operating from single MHz to the 60 GHz range, requires very accurate and thorough characterization of consumer electronics equipment. CobaltFx is a system that allows for very cost effective, accurate and flexible verification of the product at the device or system level, allowing for low cost production.

Automotive Radar & Sensor Testing

With various automotive and non-automotive radar sensors, the need for thorough characterization of devices and materials

at 77 and 79 GHz has never been greater. With adaptive cruise control (ACC), collision mitigation (CM) and pedestrian detection (PD) systems already available-and autonomous driving under development-the automotive industry is in need of cost- and time-effective test solutions for radar sensors.

Also, non-automotive 77 GHz FMCW radar applications that cover foreign object detection, perimeter and security detection, collision avoidance and moving object detection also require test and measurement systems during their development and production. CobaltFx offers the most cost effective and flexible T&M solution for radar applications on the market.

Backhaul at 70 & 80 GHz

Backhaul radio communication is another technology that will support mobile data networks and IoT in the future. The

technology provides short range 1-3 km, high speed 1-2 Gb/s radio transmission for existing mobile networks. Due to its flexibility, ease of deployment and capacity it is frequently used for point-to-point links where fiber networks are not feasible from an environmental point of view (water crossing etc.) or cost. Thorough characterization of passive and active devices (amplifiers, filters, up and down-converters, antennas) is always required as these systems must meet stringent spectrum mask requirements for licensed frequency range. CobaltFx is a system that allows for cost and time effective measurement of Backhaul components and subsystems.

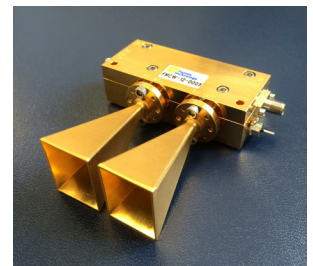

Fx FET-WR15 Extenders

Electrical Specifications

Frequency range	50 GHz to 75 GHz
Test port output power (no attenuation)	+5 dBm, typ
Test port input power (damage)	+15 dBm, max
Output power control range (for configurations with attenuator)	30 dB, typ
Dynamic range ²	100 dB, 120 dB typ
Test port match	25 dB, typ
Directivity	35 dB, typ
RF source input frequency	6.25 GHz to 9.38 GHz
RF source input power	-6 dBm, min; -3 dBm, typ; 0 dBm, max
LO source input frequency (RF+IF)	6.25 GHz to 9.38 GHz
LO source input power	-3 dBm, min; 0 dBm, typ; +3 dBm, max
IF frequency range	10 MHz to 1000 MHz
Multiplication factor	8
Magnitude stability ³	±0.1 dB, typ
Phase stability ³	±2.5°, typ
Specification temperature	+20°C to +30°C
Operating temperature	0°C to +50°C

Mechanical Specifications

Test port	WR-15 waveguide with UF-387/U precision anti-cocking flange
RF and LO source input ports	SMA (F), SMA (F)
IF output port	SMA (F)
IF reference port	SMA (F)
DC power receptacle	LEMO EGG.0B.304.CLL
Finish	Black Anodized
Weight (per module)	4.4 lb
Size (without adjustable feet)	11.50"x3"x1.9"

Simplified Block Diagram

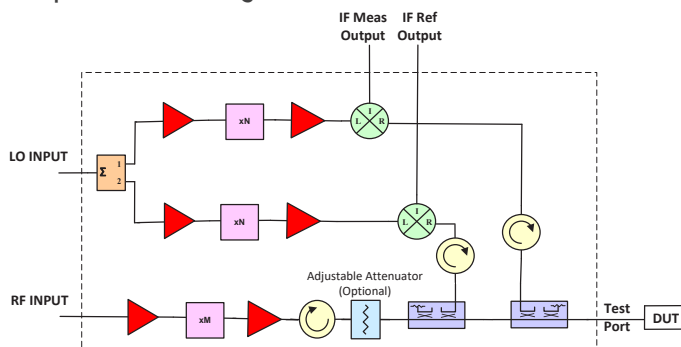

[1] All specifications subject to change without notice. **CAUTION!** Exceeding absolute maximum ratings of the device will damage the extenders. Proper torque, 8.0 ± 0.15 inch-pounds (0.90 ± 0.02 Nm), should be applied. Any foreign objects in the waveguide will cause performance degradation or damage the device. [2] Dynamic range specification at 10 Hz BW. [3] Specification at 300 Hz BW. Necessary Accessories: Each extender includes DC power supply. 4 RF cables per extender are necessary and sold separately. © Copper Mountain Technologies - www.coppermountaintech.com - 2023Q4

Dynamic Range vs Frequency

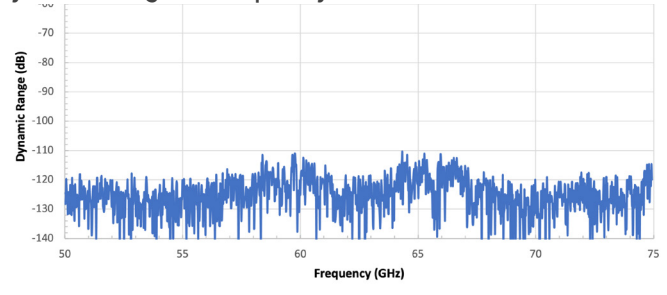

Directivity vs Frequency

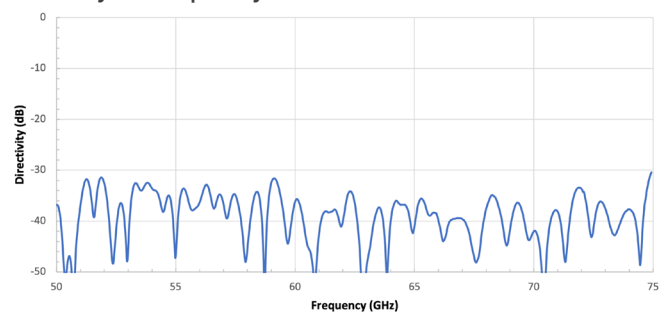

Output Power vs Frequency

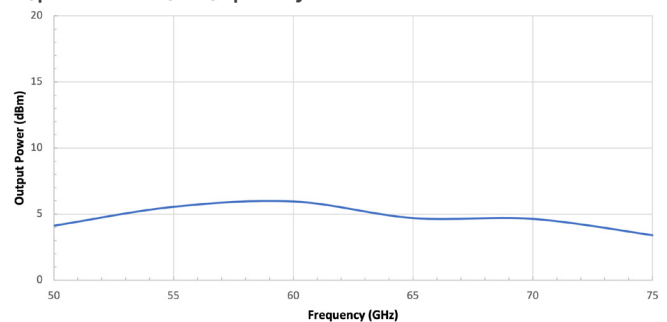

Test Port Match vs Frequency

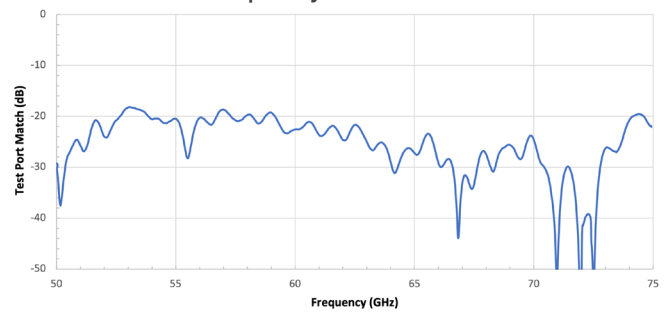

Fx FET-WR15-HP Extenders

Electrical Specifications

Frequency range	60 GHz to 90 GHz
Test port output power (no attenuation)	+15 dBm, typ
Test port input power (damage)	+25 dBm, max
Output power control range (for configurations with attenuator)	30 dB, typ
Dynamic range ²	100 dB, 120 dB typ
Test port match	25 dB, typ
Directivity	35 dB, typ
RF source input frequency	5 GHz to 7.5 GHz
RF source input power	-6 dBm, min; -3 dBm, typ; 0 dBm, max
LO source input frequency (RF+IF)	5 GHz to 7.5 GHz
LO source input power	-3 dBm, min; 0 dBm, typ; +3 dBm, max
IF frequency range	10 MHz to 1000 MHz
Multiplication factor	12
Magnitude stability ³	± 0.1 dB, typ
Phase stability ³	$\pm 2.5^\circ$, typ
Specification temperature	+20°C to +30°C
Operating temperature	0°C to +50°C

Mechanical Specifications

Test port	WR-15 waveguide with UF-387/U precision anti-cocking flange
RF and LO source input ports	SMA (F), SMA (F)
IF output port	SMA (F)
IF reference port	SMA (F)
DC power receptacle	LEMO EGG.0B.304.CLL
Finish	Black Anodized
Weight (per module)	4.4 lb
Size (without adjustable feet)	11.50"x3"x1.9"

Simplified Block Diagram

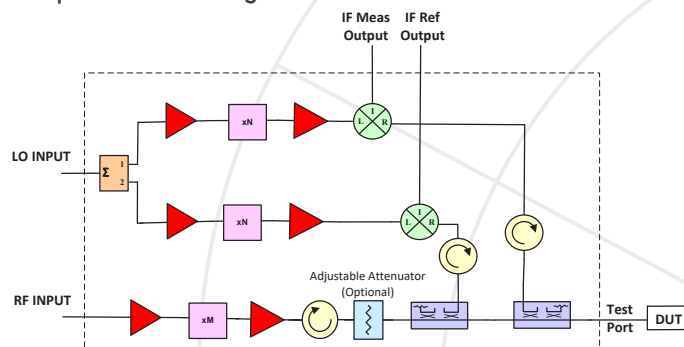

[1] All specifications subject to change without notice. **CAUTION!** Exceeding absolute maximum ratings of the device will damage the extenders. Proper torque, 8.0 ± 0.15 inch-pounds (0.90 ± 0.02 Nm), should be applied. Any foreign objects in the waveguide will cause performance degradation or damage the device. [2] Dynamic range specification at 10 Hz BW. [3] Specification at 300 Hz BW. Necessary Accessories: Each extender includes DC power supply. 4 RF cables per extender are necessary and sold separately. © Copper Mountain Technologies - www.coppermountaintech.com - 2023Q4

Dynamic Range vs Frequency

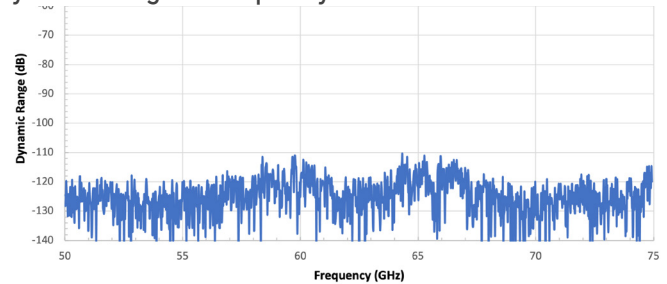

Directivity vs Frequency

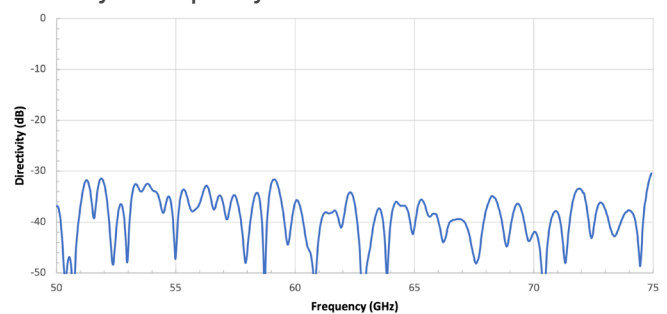

Output Power vs Frequency

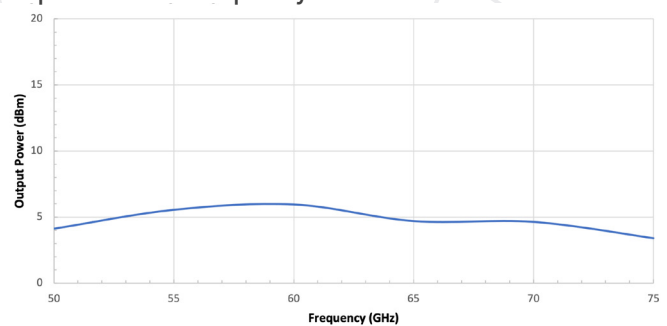

Test Port Match vs Frequency

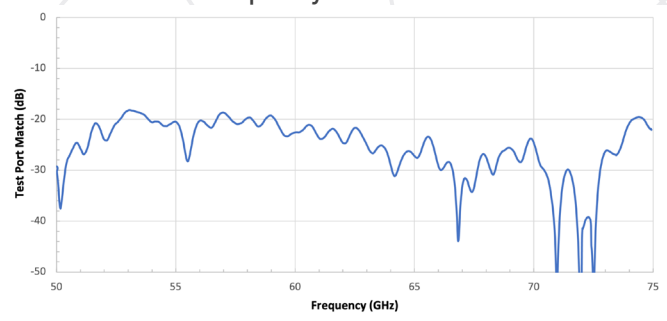

Fx FET-WR12 Extenders

Electrical Specifications

Frequency range	60 GHz to 90 GHz
Test port output power (no attenuation)	+5 dBm, typ
Test port input power (damage)	+15 dBm, max
Output power control range (for configurations with attenuator)	30 dB, typ
Dynamic range ²	100 dB, 120 dB typ
Test port match	25 dB, typ
Directivity	35 dB, typ
RF source input frequency	5 GHz to 7.5 GHz
RF source input power	-6 dBm, min; -3 dBm, typ; 0 dBm, max
LO source input frequency (RF±IF)	5 GHz to 7.5 GHz
LO source input power	-3 dBm, min; 0 dBm, typ; +3 dBm, max
IF frequency range	10 MHz to 1000 MHz
Multiplication factor	12
Magnitude stability ³	±0.1 dB, typ
Phase stability ³	±2.5°, typ
Specification temperature	+20°C to +30°C
Operating temperature	0°C to +50°C

Mechanical Specifications

Test port	WR-12 waveguide with UF-387/U precision anti-cocking flange
RF and LO source input ports	SMA (F), SMA (F)
IF output port	SMA (F)
IF reference port	SMA (F)
DC power receptacle	LEMO EGG.0B.304.CLL
Finish	Black Anodized
Weight (per module)	4.4 lb
Size (without adjustable feet)	11.50"x3"x1.9"

Simplified Block Diagram

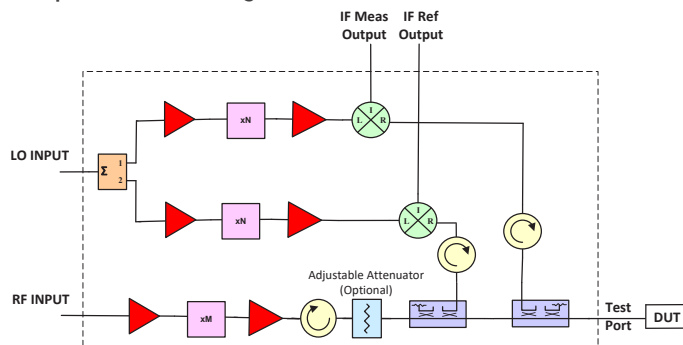

[1] All specifications subject to change without notice. **CAUTION!** Exceeding absolute maximum ratings of the device will damage the extenders. Proper torque, 8.0 ± 0.15 inch-pounds (0.90 ± 0.02 Nm), should be applied. Any foreign objects in the waveguide will cause performance degradation or damage the device. [2] Dynamic range specification at 10 Hz BW. [3] Specification at 300 Hz BW. Necessary Accessories: Each extender includes DC power supply. 4 RF cables per extender are necessary and sold separately. © Copper Mountain Technologies - www.coppermountaintech.com - Rev. 2023Q4

Dynamic Range vs Frequency

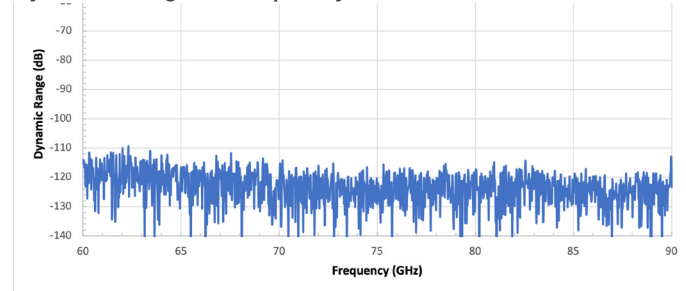

Directivity vs Frequency

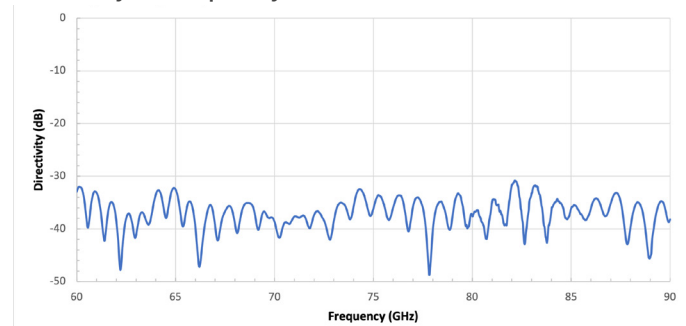

Output Power vs Frequency

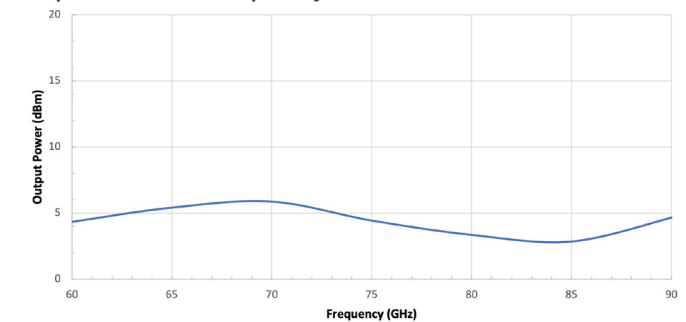

Test Port Match vs Frequency

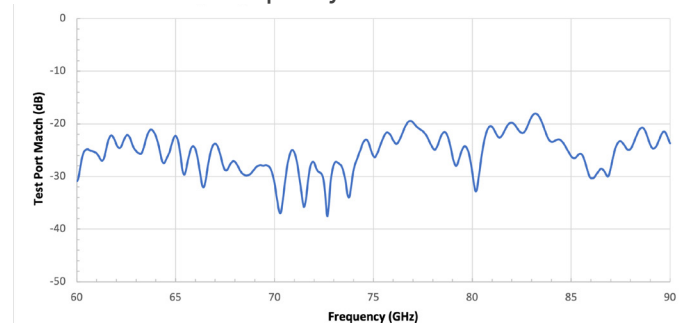

Fx FET-WR12-HP Extenders

Electrical Specifications

Frequency range	50 GHz to 75 GHz
Test port output power (no attenuation)	+15 dBm, typ
Test port input power (damage)	+25 dBm, max
Output power control range (for configurations with attenuator)	30 dB, typ
Dynamic range ²	100 dB, 120 dB typ
Test port match	25 dB, typ
Directivity	35 dB, typ
RF source input frequency	6.25 GHz to 9.38 GHz
RF source input power	-6 dBm, min; -3 dBm, typ; 0 dBm, max
LO source input frequency (RF+IF)	6.25 GHz to 9.38 GHz
LO source input power	-3 dBm, min; 0 dBm, typ; +3 dBm, max
IF frequency range	10 MHz to 1000 MHz
Multiplication factor	8
Magnitude stability ³	±0.1 dB, typ
Phase stability ³	±2.5°, typ
Specification temperature	+20°C to +30°C
Operating temperature	0°C to +50°C

Mechanical Specifications

Test port	WR-12 waveguide with UF-387/U precision anti-cocking flange
RF and LO source input ports	SMA (F), SMA (F)
IF output port	SMA (F)
IF reference port	SMA (F)
DC power receptacle	LEMO EGG.0B.304.CLL
Finish	Black Anodized
Weight (per module)	4.4 lb
Size (without adjustable feet)	11.50"x3"x1.9"

Simplified Block Diagram

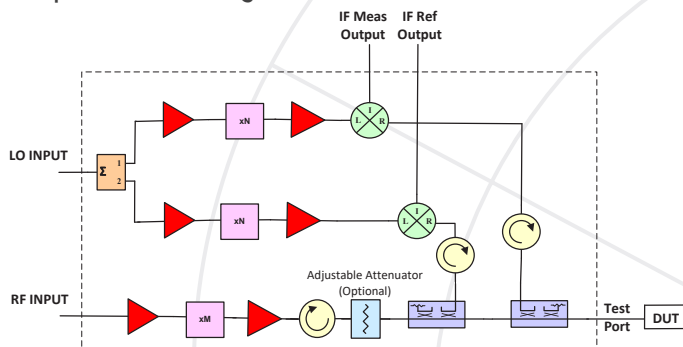

[1] All specifications subject to change without notice. **CAUTION!** Exceeding absolute maximum ratings of the device will damage the extenders. Proper torque, 8.0 ± 0.15 inch-pounds (0.90 ± 0.02 Nm), should be applied. Any foreign objects in the waveguide will cause performance degradation or damage the device. [2] Dynamic range specification at 10 Hz BW. [3] Specification at 300 Hz BW. Necessary Accessories: Each extender includes DC power supply. 4 RF cables per extender are necessary and sold separately. © Copper Mountain Technologies - www.coppermountaintech.com - Rev. 2023Q4

Dynamic Range vs Frequency

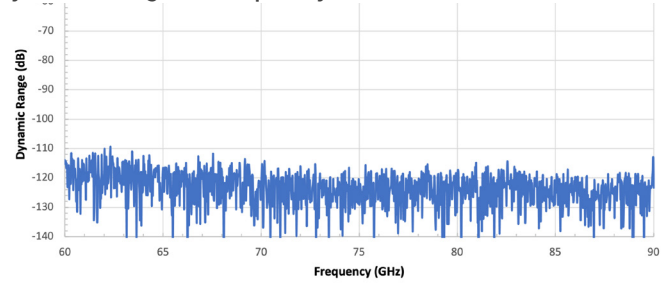

Directivity vs Frequency

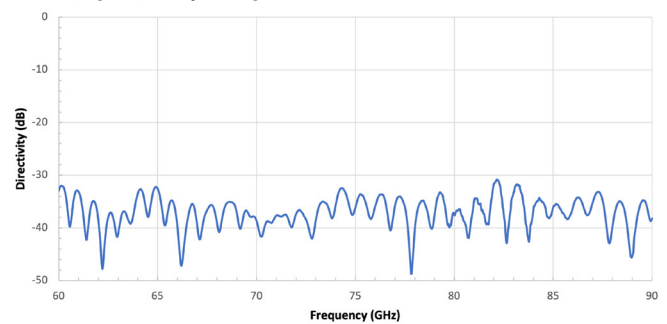

Output Power vs Frequency

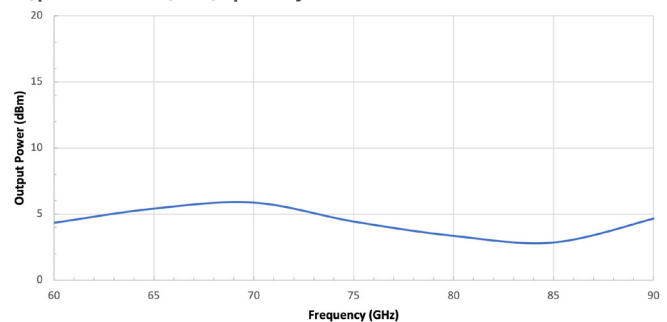

Test Port Match vs Frequency

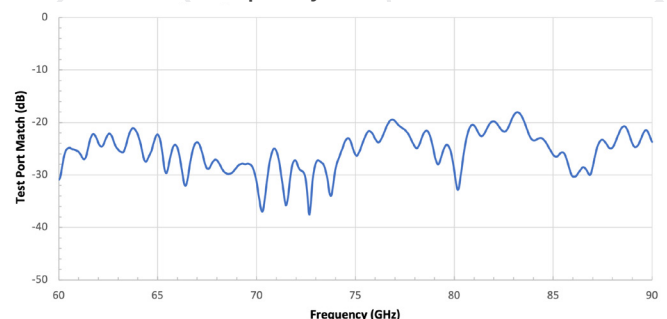

Fx FET-WR10 Extenders

Electrical Specifications

Frequency range	75 GHz to 110 GHz
Test port output power (no attenuation)	+5 dBm, typ
Test port input power (damage)	+20 dBm, max
Output power control range (for configurations with attenuator)	30 dB, typ
Dynamic range ²	100 dB, 120 dB typ
Test port match	25 dB, typ
Directivity	35 dB, typ
RF source input frequency	6.25 GHz to 9.17 GHz
RF source input power	-6 dBm, min; -3 dBm, typ; 0 dBm, max
LO source input frequency (RF+IF)	6.25 GHz to 9.17 GHz
LO source input power	-3 dBm, min; 0 dBm, typ; +3 dBm, max
IF frequency range	10 MHz to 1000 MHz
Multiplication factor	12
Magnitude stability ³	±0.1 dB, typ
Phase stability ³	±2.5°, typ
Specification temperature	+20°C to +30°C
Operating temperature	0°C to +50°C

Mechanical Specifications

Test port	WR-10 waveguide with UF-387/U-M precision anti-cocking flange
RF and LO source input ports	SMA (F), SMA (F)
IF output port	SMA (F)
IF reference port	SMA (F)
DC power receptacle	LEMO EGG.0B.304.CLL
Finish	Black Anodized
Weight (per module)	4.4 lb
Size (without adjustable feet)	11.50"x3"x1.9"

Simplified Block Diagram

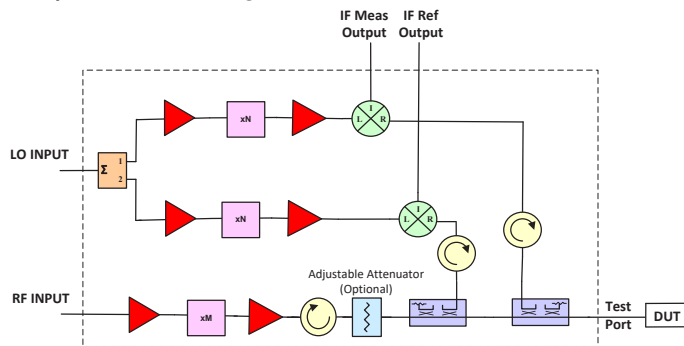

[1] All specifications subject to change without notice. **CAUTION!** Exceeding absolute maximum ratings of the device will damage the extenders. Proper torque, 8.0 ± 0.15 inch-pounds (0.90 ± 0.02 Nm), should be applied. Any foreign objects in the waveguide will cause performance degradation or damage the device. [2] Dynamic range specification at 10 Hz BW. [3] Specification at 300 Hz BW. Necessary Accessories: Each extender includes DC power supply. 4 RF cables per extender are necessary and sold separately. © Copper Mountain Technologies - www.coppermountaintech.com - Rev. 2023Q4

Dynamic Range vs Frequency

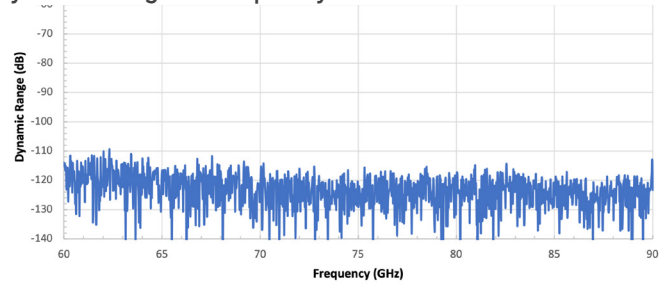

Directivity vs Frequency

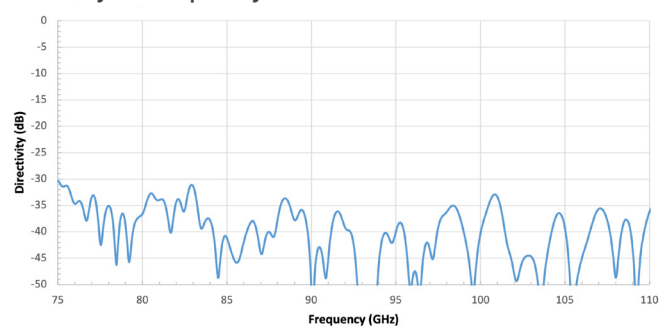

Test Port Power vs Frequency

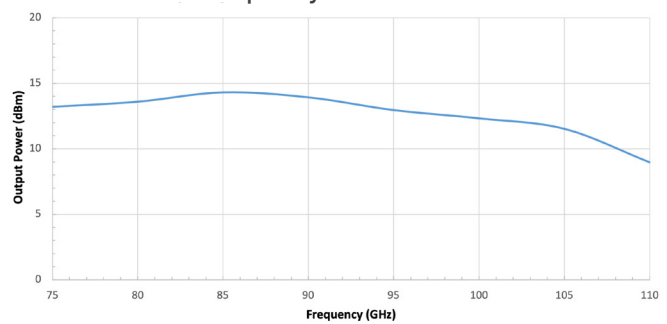

Test Port Match vs Frequency

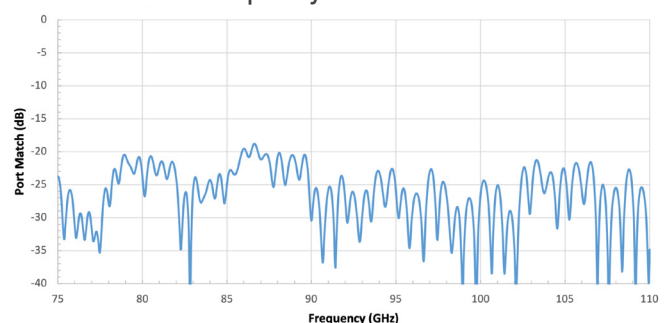

Fx FET-WR10-HP Extenders

Electrical Specifications

Frequency range	75 GHz to 110 GHz
Test port output power (no attenuation)	+13 dBm, typ
Test port input power (damage)	+30 dBm, max
Output power control range (for configurations with attenuator)	30 dB, typ
Dynamic range ²	100 dB, 120 dB typ
Test port match	25 dB, typ
Directivity	35 dB, typ
RF source input frequency	6.25 GHz to 9.17 GHz
RF source input power	-6 dBm, min; -3 dBm, typ; 0 dBm, max
LO source input frequency (RF+IF)	6.25 GHz to 9.17 GHz
LO source input power	-3 dBm, min; 0 dBm, typ; +3 dBm, max
IF frequency range	10 MHz to 1000 MHz
Multiplication factor	12
Magnitude stability ³	±0.1 dB, typ
Phase stability ³	±2.5°, typ
Specification temperature	+20°C to +30°C
Operating temperature	0°C to +50°C

Mechanical Specifications

Test port	WR-10 waveguide with UF-387/U-M precision anti-cocking flange
RF and LO source input ports	SMA (F), SMA (F)
IF output port	SMA (F)
IF reference port	SMA (F)
DC power receptacle	LEMO EGG.0B.304.CLL
Finish	Black Anodized
Weight (per module)	4.4 lb
Size (without adjustable feet)	11.50"x3"x1.9"

Simplified Block Diagram

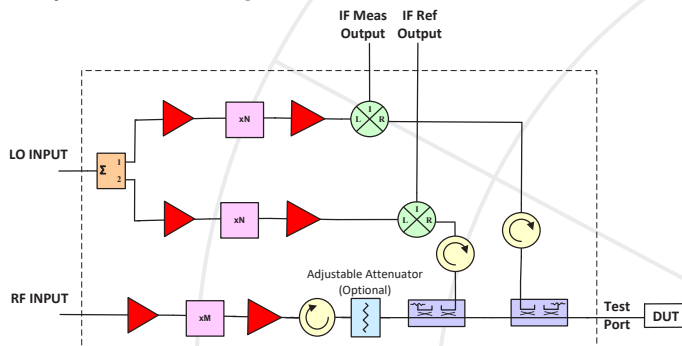

[1] All specifications subject to change without notice. **CAUTION!** Exceeding absolute maximum ratings of the device will damage the extenders. Proper torque, 8.0 ± 0.15 inch-pounds (0.90 ± 0.02 Nm), should be applied. Any foreign objects in the waveguide will cause performance degradation or damage the device. [2] Dynamic range specification at 10 Hz BW. [3] Specification at 300 Hz BW. Necessary Accessories: Each extender includes DC power supply. 4 RF cables per extender are necessary and sold separately. © Copper Mountain Technologies - www.coppermountaintech.com - Rev. 2023Q4

Dynamic Range vs Frequency

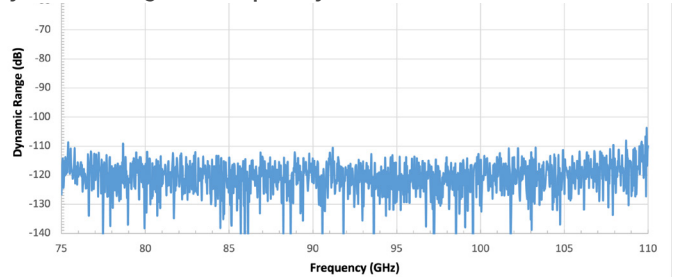

Directivity vs Frequency

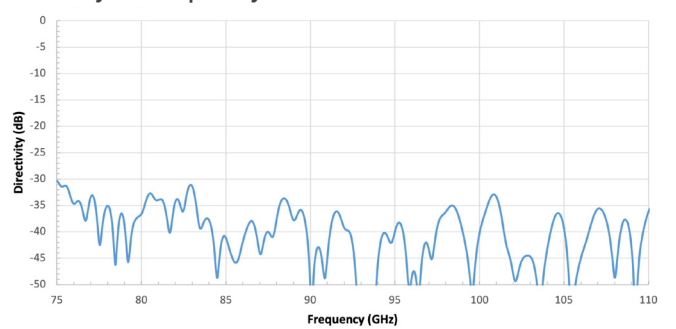

Test Port Power vs Frequency

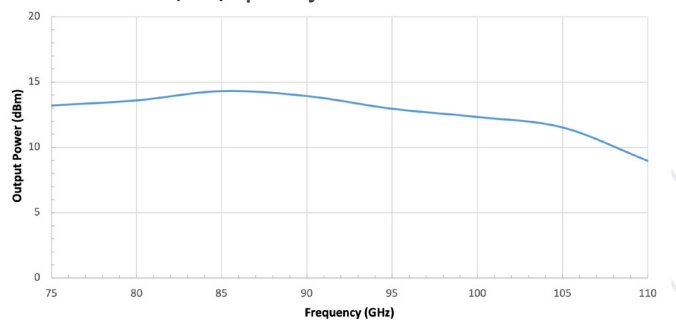

Test Port Match vs Frequency

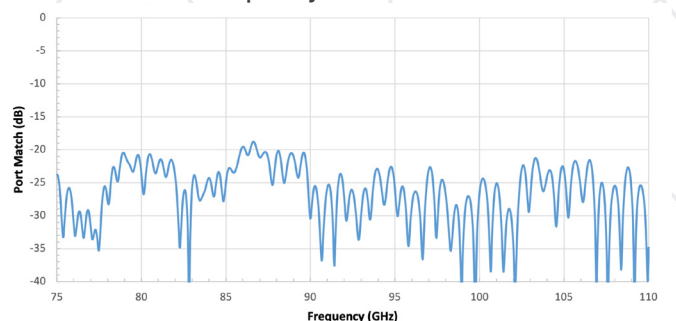

Fx FET-WR08 Extenders

Electrical Specifications

Frequency range	90 GHz to 140 GHz
Test port output power (no attenuation)	-5 dBm, typ
Test port input power (damage)	+25 dBm, max
Output power control range (for configurations with attenuator)	30 dB, typ
Dynamic range ²	100 dB, typ
Test port match	25 dB, typ
Directivity	30 dB, typ
RF source input frequency	5.63 GHz to 8.75 GHz
RF source input power	-6 dBm, min; -3 dBm, typ; 0 dBm, max
LO source input frequency (RF+IF)	5.63 GHz to 8.75 GHz
LO source input power	-3 dBm, min; 0 dBm, typ; +3 dBm, max
IF frequency range	10 MHz to 1000 MHz
Multiplication factor	16
Magnitude stability ³	± 0.15 dB, typ
Phase stability ³	$\pm 3^\circ$, typ
Specification temperature	+20°C to +30°C
Operating temperature	0°C to +50°C

Mechanical Specifications

Test port	WR-08 waveguide with UF-387/U precision anti-cocking flange
RF and LO source input ports	SMA (F), SMA (F)
IF output port	SMA (F)
IF reference port	SMA (F)
DC power receptacle	LEMO EGG.0B.304.CLL
Finish	Black Anodized
Weight (per module)	4.4 lb
Size (without adjustable feet)	11.50"x3"x1.9"

Simplified Block Diagram

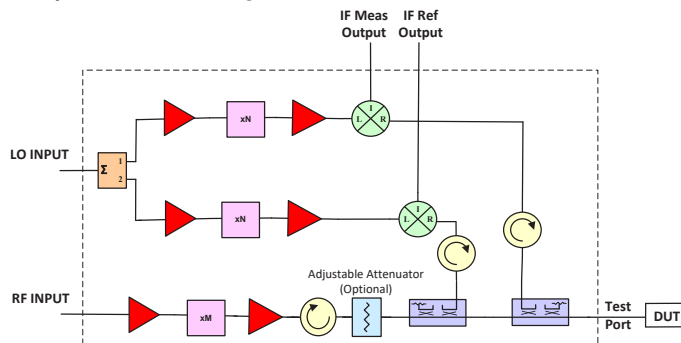

Dynamic Range vs. Frequency

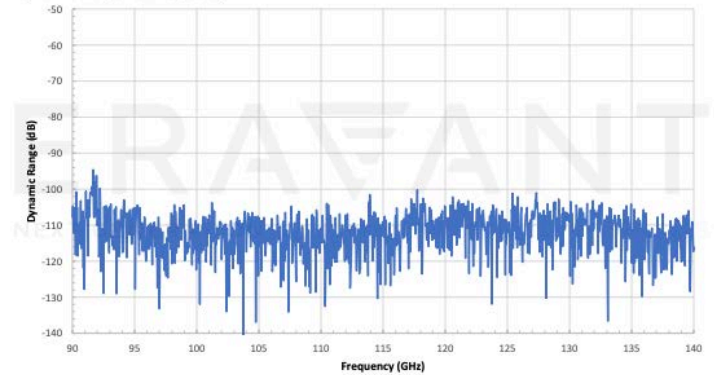

Directivity vs. Frequency

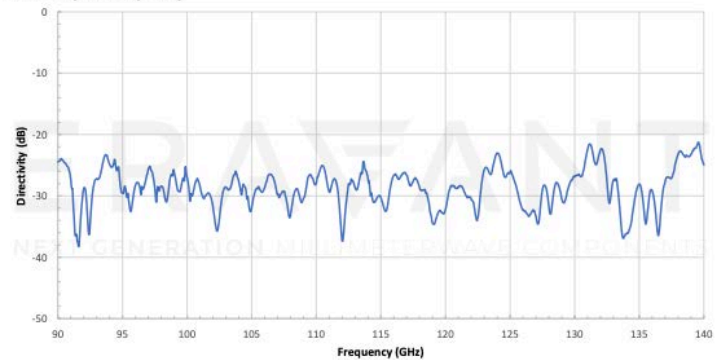

Test Port Match vs. Frequency

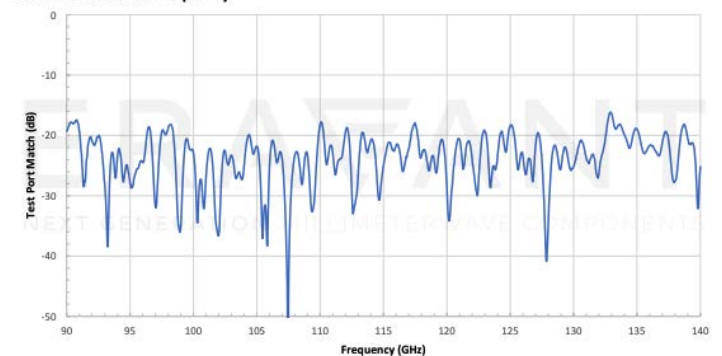

[1] All specifications subject to change without notice. **CAUTION!** Exceeding absolute maximum ratings of the device will damage the extenders. Proper torque, 8.0 ± 0.15 inch-pounds (0.90 ± 0.02 Nm), should be applied. Any foreign objects in the waveguide will cause performance degradation or damage the device. [2] Dynamic range specification at 10 Hz BW. [3] Specification at 300 Hz BW. Necessary Accessories: Each extender includes DC power supply. 4 RF cables per extender are necessary and sold separately. © Copper Mountain Technologies -www.coppermountaintech.com - Rev. 2023Q4

Fx FET-WR06 Extenders

Electrical Specifications

Frequency range	110 GHz to 170 GHz
Test port output power (no attenuation)	-5 dBm, typ
Test port input power (damage)	+25 dBm, max
Output power control range (for configurations with attenuator)	30 dB, typ
Dynamic range ²	100 dB, typ
Test port match	25 dB, typ
Directivity	25 dB, typ
RF source input frequency	4.58 GHz to 7.08 GHz
RF source input power	-6 dBm, min; -3 dBm, typ; 0 dBm, max
LO source input frequency (RF±IF)	4.58 GHz to 7.08 GHz
LO source input power	-3 dBm, min; 0 dBm, typ; +3 dBm, max
IF frequency range	10 MHz to 1000 MHz
Multiplication factor	24
Magnitude stability ³	±0.20 dB, typ
Phase stability ³	+4°, typ
Specification temperature	+20°C to +30°C
Operating temperature	0°C to +50°C

Mechanical Specifications

Test port	WR-06 waveguide with UF-387/U precision anti-cocking flange
RF and LO source input ports	SMA (F), SMA (F)
IF output port	SMA (F)
IF reference port	SMA (F)
DC power receptacle	LEMO EGG.0B.304.CLL
Finish	Cobalt Blue Anodized
Weight (per module)	4.4 lb
Size (without adjustable feet)	11.50"x3"x1.9"

Simplified Block Diagram

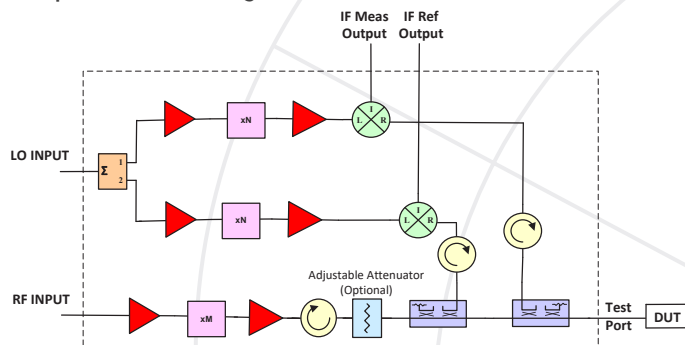

Test Port Power vs. Frequency

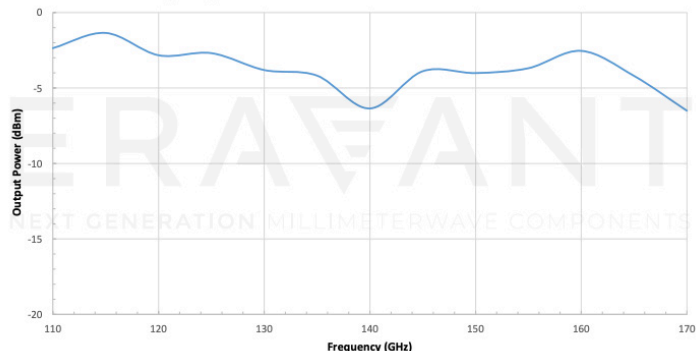

Port Match vs. Frequency

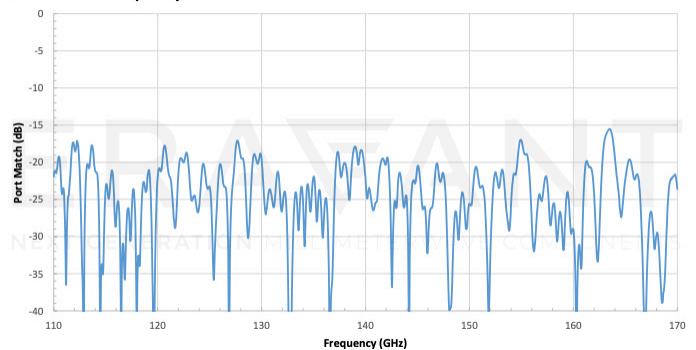

Dynamic Range vs. Frequency

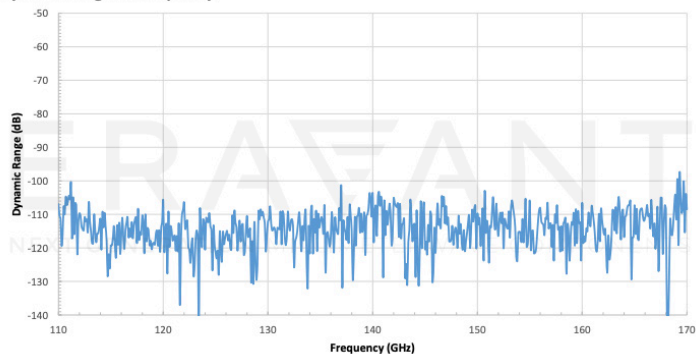

Directivity vs. Frequency

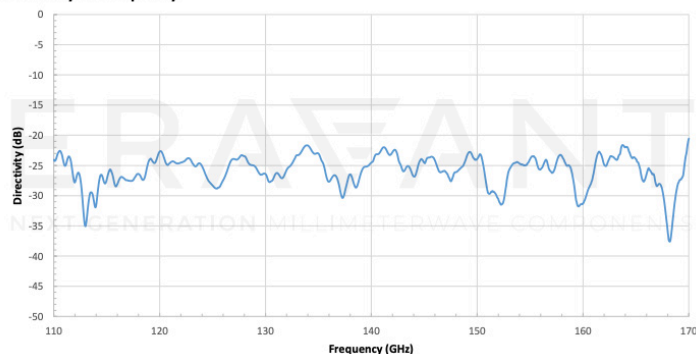

[1] All specifications subject to change without notice. **CAUTION!** Exceeding absolute maximum ratings of the device will damage the extenders. Proper torque, 8.0 ± 0.15 inch-pounds (0.90 ± 0.02 Nm), should be applied. Any foreign objects in the waveguide will cause performance degradation or damage the device. [2] Dynamic range specification at 10 Hz BW. [3] Specification at 300 Hz BW. Necessary Accessories: Each extender includes DC power supply. 4 RF cables per extender are necessary and sold separately. © Copper Mountain Technologies - www.coppermountaintech.com - Rev. 2023Q4

Fx FET-WR05 Extenders

Electrical Specifications

Frequency range	140 GHz to 220 GHz
Test port output power (no attenuation)	-5 dBm, typ
Test port input power (damage)	+25 dBm, max
Output power control range (for configurations with attenuator)	30 dB, typ
Dynamic range ²	100 dB, typ
Test port match	25 dB, typ
Directivity	25 dB, typ
RF source input frequency	6.25 GHz to 9.17 GHz
RF source input power	-6 dBm, min; -3 dBm, typ; 0 dBm, max
LO source input frequency (RF+IF)	6.25 GHz to 9.17 GHz
LO source input power	-3 dBm, min; 0 dBm, typ; +3 dBm, max
IF frequency range	10 MHz to 1000 MHz
Multiplication factor	24
Magnitude stability ³	± 0.25 dB, typ
Phase stability ³	$\pm 5^\circ$, typ
Specification temperature	+20°C to +30°C
Operating temperature	0°C to +50°C

Mechanical Specifications

Test port	WR-05 waveguide with UF-387/U precision anti-cocking flange
RF and LO source input ports	SMA (F), SMA (F)
IF output port	SMA (F)
IF reference port	SMA (F)
DC power receptacle	LEMO EGG.0B.304.CLL
Finish	Cobalt Blue Anodized
Weight (per module)	4.4 lb
Size (without adjustable feet)	11.50"x3"x1.9"

Simplified Block Diagram

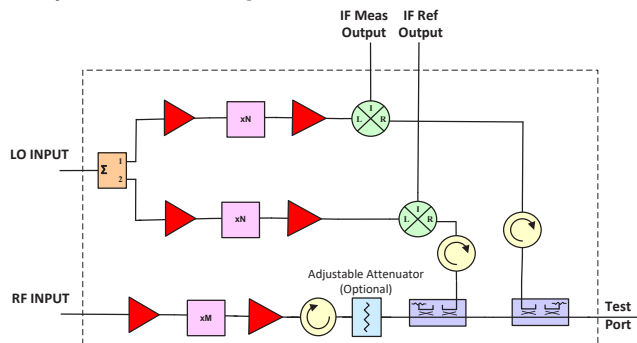

Directivity vs. Frequency

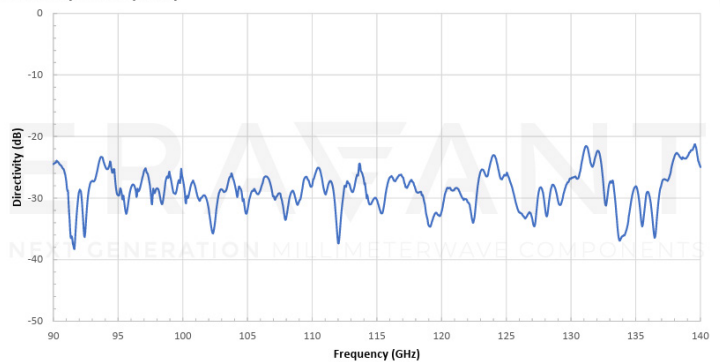

Dynamic Range vs. Frequency

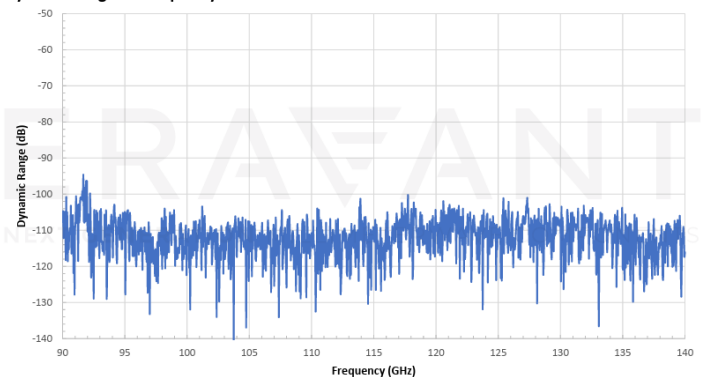

Output Power vs. Frequency

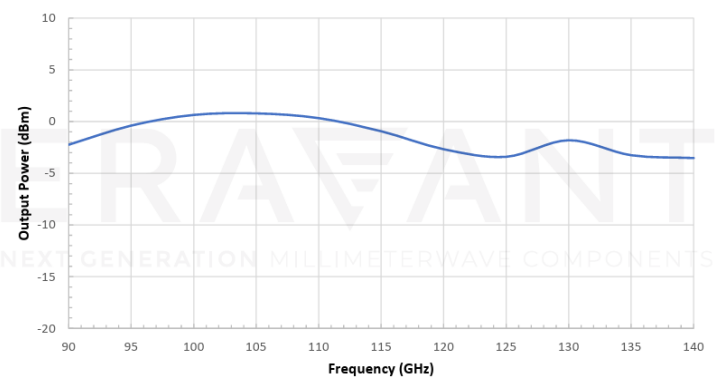

Test Port Match vs. Frequency

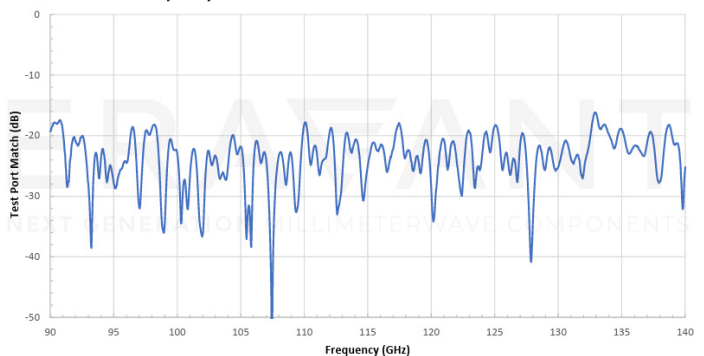

[1] All specifications subject to change without notice. **CAUTION!** Exceeding absolute maximum ratings of the device will damage the extenders. Proper torque, 8.0 ± 0.15 inch-pounds (0.90 ± 0.02 Nm), should be applied. Any foreign objects in the waveguide will cause performance degradation or damage the device. [2] Dynamic range specification at 10 Hz BW. [3] Specification at 300 Hz BW. Necessary Accessories: Each extender includes DC power supply. 4 RF cables per extender are necessary and sold separately. © Copper Mountain Technologies - www.coppermountaintech.com - Rev. 2023Q4

Recommended Accessories

WR-15 Calibration Kit

WR-12 Calibration Kit

WR-10 Calibration Kit

Operating Frequency Range	50 GHz to 75 GHz	60 GHz to 90 GHz	75 GHz to 110 GHz
Fixed Load VSWR	1.06:1 (Max)	1.06:1 (Max)	1.065:1 (Max)
Fixed Load Power Handling	0.2 Watts (Max)	0.2 Watts (Max)	0.2 Watts (Max)
Included Hardware Quantity	11	11	11
Waveguide Material	Beryllium Copper (BeCu)	Beryllium Copper (BeCu)	Beryllium Copper (BeCu)
Waveguide Finish	Gold Plated, MIL-G-45204 or ASTM B488	Gold Plated, MIL-G-45204 or ASTM B488	Gold Plated, MIL-G-45204 or ASTM B488
Size	214 mm x 172 mm x 98 mm	214 mm x 172 mm x 98 mm	214 mm x 172 mm x 98 mm
Metrology Fixed Short	1 Piece	1 Piece	1 Piece
Metrology Fixed Waveguide Load	1 Piece	1 Piece	1 Piece
Metrology 1/8 Wavelength Offset	1 Piece	1 Piece	1 Piece
Metrology 1/4 Wavelength Offset	1 Piece	1 Piece	1 Piece
Metrology 3/8 Wavelength Offset	1 Piece	1 Piece	1 Piece
Waveguide Quick Connect, 0.75" Diameter Flange	2 Pieces	2 Pieces	2 Pieces
Waveguide Screws, 3/32 Hex Head	1 Bag (10 Pieces)	1 Bag (10 Pieces)	1 Bag (10 Pieces)
Extended Waveguide Screws, 3/32 Hex Head	6 Pieces	6 Pieces	6 Pieces
Alignment Dowel Pin	4 Pieces	4 Pieces	4 Pieces
Waveguide Screwdriver, 3/32 Hex Head	1 Piece	1 Piece	1 Piece
Calibration Data, USB Driver	1 Piece	1 Piece	1 Piece

WR-08 Calibration Kit

Operating Frequency Range	90 GHz to 140 GHz
Fixed Load VSWR	1.065:1 (Max)
Fixed Load Power Handling	0.2 Watts (Max)
Included Hardware Quantity	11
Waveguide Material	Beryllium Copper (BeCu)
Waveguide Finish	Gold Plated, MIL-G-45204 or ASTM B488
Size	214 mm x 172 mm x 98 mm
Metrology Fixed Short	1 Piece
Metrology Fixed Waveguide Load	1 Piece
Metrology 1/8 Wavelength Offset	1 Piece
Metrology 1/4 Wavelength Offset	1 Piece
Metrology 3/8 Wavelength Offset	1 Piece
Waveguide Quick Connect, 0.75" Diameter Flange	2 Pieces
Waveguide Screws, 3/32 Hex Head	1 Bag (10 Pieces)
Extended Waveguide Screws, 3/32 Hex Head	6 Pieces
Alignment Dowel Pin	4 Pieces
Waveguide Screwdriver, 3/32 Hex Head	1 Piece
Calibration Data, USB Driver	1 Piece

Proxi-Flange Kit



Waveguide Rail



Quik-Connect with Stand





Technology is supposed to move. It's supposed to change and update and progress. It's not meant to sit stagnant year after year simply because that's how things have always been done.

The engineers at Copper Mountain Technologies are creative problem solvers. They know the people using VNAs don't just need one giant machine in a lab. They know that VNAs are needed in the field, requiring portability and flexibility. Data needs to be quickly transferred, and a test setup needs to be easily automated and recalled for various applications. The engineers at Copper Mountain Technologies are rethinking the way VNAs are developed and used.

Copper Mountain Technologies' VNAs are designed to work with the Windows or Linux PC you already use via USB interface. After installing the test software, you have a top-quality VNA at a fraction of the cost of a traditional analyzer. The result is a faster, more effective test process that fits into the modern workspace. This is the creativity that makes Copper Mountain Technologies stand out above the crowd.

 ***We're creative. We're problem solvers.***



631 E. New York Street
Indianapolis, IN 46202

United States: +1.317.222.5400
Latin America: +1.954.706.5920

APAC: +65.63.23.6546
EMEA: +44 75 03 69 21 13