

# Rack Mount Kit C1209 Assembly Instructions

- VNA C1209
- Rack Mount Kit 1209
- Phillips Screwdriver

**STEP 1**

Unscrew 8 pcs. M4 × 16 screws on the front handles on the device case. Remove the handles.

**STEP 2**

Install the rack mount kit and fix with the same screws according to Figure 1.

**STEP 3**

Place the device with the rack mount kit installed in a 19" rack and attach it according to Figure 2.

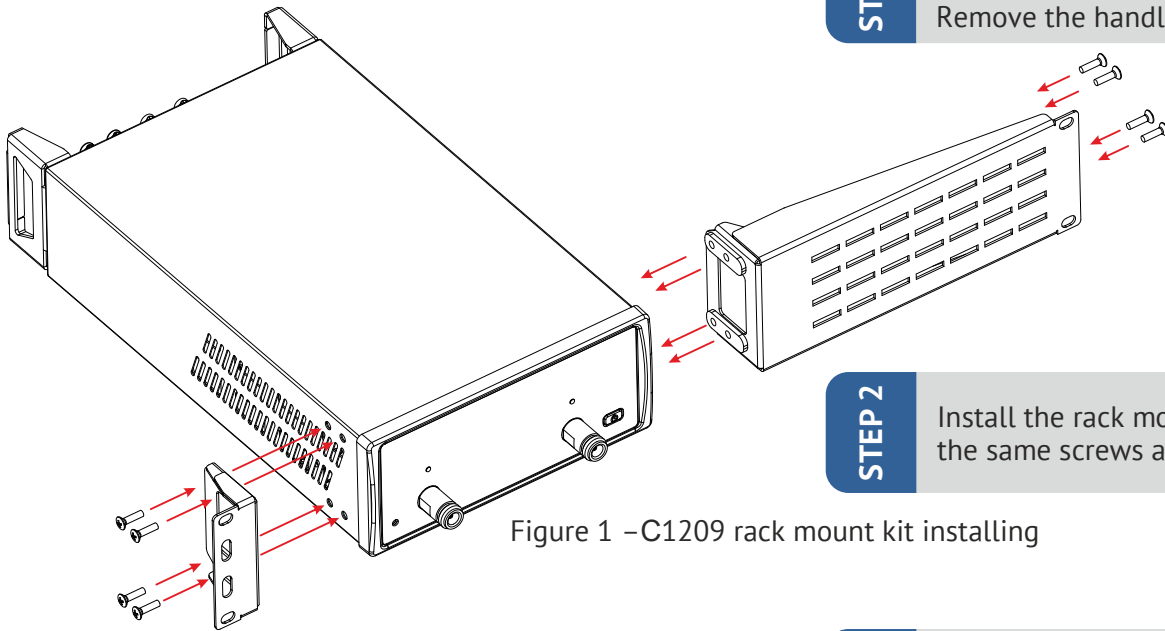

Figure 1 - C1209 rack mount kit installing

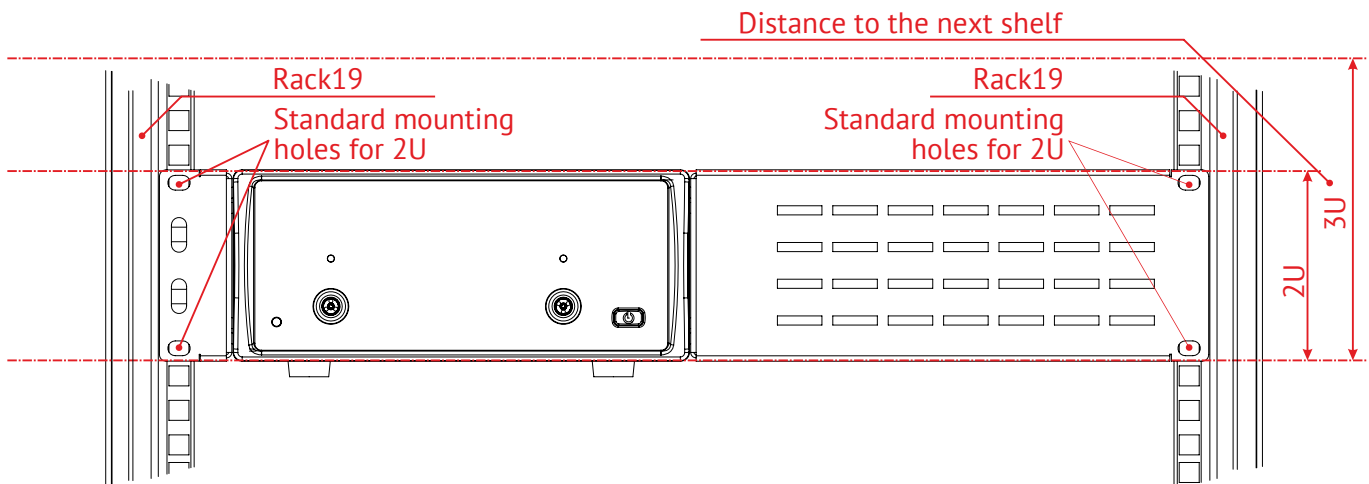

Figure 2 - Installing the device in a rack

R0063 V0

